



WILDCAT CONNECTORS FOR UNMANNED AUTONOMOUS VEHICLES (UAV)

Unmanned but Securely Connected

Contents



WILDCAT CONNECTORS FOR UNMANNED AUTONOMOUS VEHICLES (UAV)	3
PRODUCT OVERVIEW	4
WILDCAT UAV SIZE 1 MICRO XTRALITE HE 4 WAY CONNECTOR	6
WILDCAT UAV MICRO XTRALITE HE 3 WAY CONNECTOR	8
WILDCAT UAV MICRO XTRALITE HE 5 WAY CONNECTOR	10
WILDCAT UAV MICRO XTRALITE HE 6 WAY CONNECTOR	12
WILDCAT UAV MICROLITE HE (UAVL) SERIES CONNECTORS	14
WILDCAT UAV DOUBLE DENSITY (UAVDD) SERIES CONNECTORS	16
WILDCAT UAV STANDARD SERIES CONNECTORS	18
HALF FLANGE	24
OTHER RELATED PRODUCTS	25
HOW TO ORDER	27
REFERENCE GUIDE	28
WIRE PREPARATION	30
CONTACT INSERTION/EXTRACTION	31

Wildcat Connectors for Unmanned Autonomous Vehicles (UAV)



Consistently Leading the Way in Research, Development, Innovation, Reliability and Service

TE Connectivity (TE) with its Wildcat UAV connection systems offers expertise in the design and manufacture of interconnection solutions for harsh environments. With over 40-years of international experience, Wildcat UAV connectors are designed for applications within the aerospace, defense, transportation markets. With a new black zinc nickel plating, these connectors are suitable for UAV systems.

TE Connectivity (TE) with its Wildcat UAV connectors continues to push the boundaries of technology and innovation, consistently driving the market forwards with new products that match the ever increasing demands of lower weight, smaller size and better performance. All Wildcat UAV connectors are thermal cycle tested and environmentally sealed to IP67 when mated*. All Wildcat UAV connectors also offer:

- Compact design/minimum space envelope
- Interfacial & wire sealing
- Boot termination feature
- PCB option
- Universal option available (not UAV Composite)
- Standard crimp tooling
- Suitable for blind mating
- Visual indication of keyway orientation of connector* Scoop-proof interface
- Shell-to-shell grounding (not UAV Composite)
- Positive locking coupling mechanism
- No need for backshells or boot termination
- In-line and two hole mounting styles (not UAV Composite)
- Surface finishing options
- Keyway options.

Materials

Shell / coupling ring: High strength aluminum alloy with a conductive black zinc nickel finish*

Contacts: Gold plated crimp contacts**

Insulators: Thermoplastic

Interface / wire seals: Fluorinated silicone.

RoHS and REACH compliant

*Except hermetic and UAVC connectors

**Except hermetic connectors

Vibration

All connectors aimed at autonomous solutions undergo three rigorous in-house tests for vibration and all exceed the following:

Dynamic test - random on random 60g RMS in 3 axis.

Endurance test - random 57g RMS in 2 axis for 8 hours each axis.

Sinusoidal resonance to over 75g.

Fluid Resistance

All connectors aimed at autonomous solutions show no damage when exposed to fuels, oils, and cleaning fluids regularly used in this harsh environment.

*1 meter for 30 minutes minimum

Product Overview



Wildcat UAV Micro Xtra^{LITE} HE (UAV) Series Connectors

The UAV Micro Xtra^{LITE} HE connectors offer one of the smallest, lightest packages for three, four, five and six wires. The UAV Micro Xtra^{LITE} HE 6-way is the shortest, lightest UAV connector for six wires, offering a solution where space is at its most restrictive. Refer to pages 8, 10, 12, 14, and 16 for technical specifications.



Wildcat UAV Micro^{LITE} HE (UAVL) Series Connectors

The Micro^{LITE} HE range is lighter and smaller than the original Wildcat UAV Micro HE connector, while still retaining all critical features such as vibration, temperature, and chemical resistance. Refer to page 18 for technical specifications.



Wildcat UAV Mini Series Connectors

The Wildcat UAV Mini Series connector bridges the gap between the existing standard Wildcat UAV Series (Size 8) and the Wildcat UAV Micro range (Size 6), offering 6-way and 3-way connectors in three shell styles. Refer to page 20 for technical specifications.

Product Overview (continued)



Wildcat UAV Double Density (UAVDD) Series Connectors

Next generation connector technology which brings together high density and high performance, inline with using wire size down to AWG 30. The Wildcat UAV Double Density range allows almost double the number of contacts to be packaged in the same shell as compared to the standard Wildcat UAV Series connectors. Refer to page 22 for technical specifications.



Wildcat UAV Standard Series Connectors

Developed by TE's engineers from the MIL-C-38999 Series 1.5 (Eurofighter connector), the Wildcat UAV Series connector was the first range of high specification connectors designed for the autonomous market. TE Wildcat UAV Series connector offers weight and space saving over standard military designs and is available a wide variety of options, with medium and high density arrangements up to 128 ways with four shell styles, and five keyway orientations. Refer to page 24 for technical specifications.



Wildcat UAV Heavy Duty (UAVHD) Series Connectors

A range of power connectors designed specifically for high current applications. The Wildcat UAV Heavy Duty connectors are ideally suited to high power battery and motor applications. Specially designed low insertion / extraction force contacts help ensure maximum performance in extreme conditions. Refer to page 30 for technical specifications.

Related Products

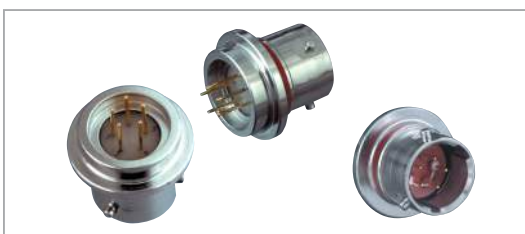

Wildcat UAV Micro HE Hermetic Series Connectors

- Filtered Hermetic option also available
- Stainless Steel (316) for ease of mounting and corrosion performance
- Titanium versions for light weight applications also available
- Glass seal can withstand pressure differentials of 1000 psi without loss of electrical performance or fluid leakage

Refer to page 33 for additional information on related products.

Wildcat UAV Size 1 Micro Xtra^{LITE} HE 4 Way Connector

Ultra compact design (size 01 shell)

- Minimum space envelope
- 4 contacts Size #24
- PCB option
- Smaller and lighter than Wildcat UAV Ultra^{LITE} (UAVU) series connectors

- Scoop proof interface
- Boot termination feature

Built to withstand harsh environments

- Conductive black zinc nickel finish
- Interfacial wire sealing
- Bonded and sealed insert to help prevent moisture ingress

Easy installation

- Positive locking coupling mechanism
- Suitable for blind mating

Plug Assembly

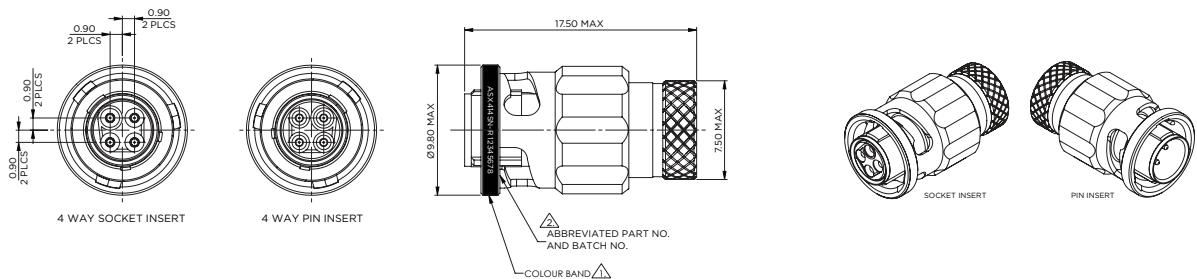

Receptacle Assembly, 2-Hole Flange

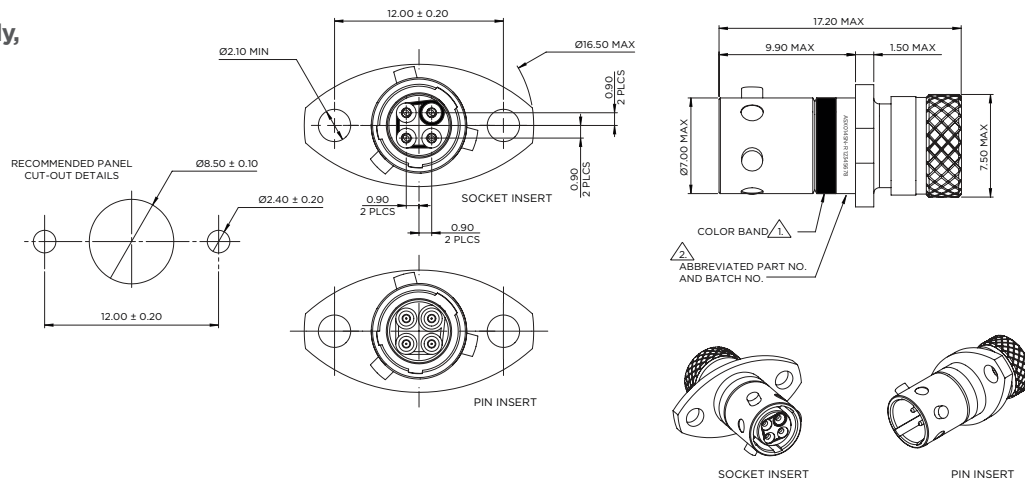

Receptacle Assembly, Half Flange

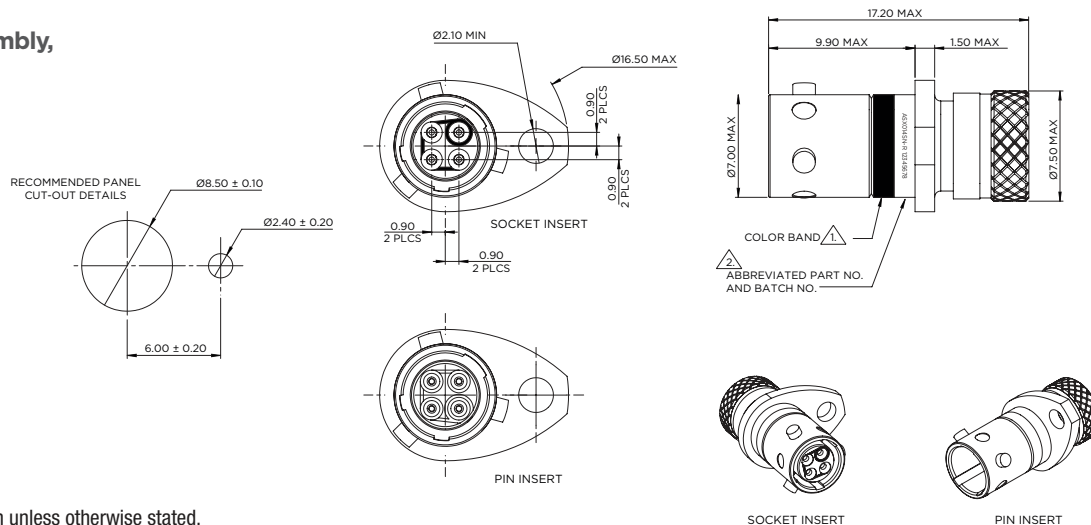

All dimensions are in mm unless otherwise stated.

Wildcat UAV Size 1 Micro Xtra^{LITE} HE 4 Way Connector

GENERAL SPECIFICATION

No. of Ways	Contact Size	Shell Size	Max. Current (Amps)	Durability (cycles of engagement & disengagement)	Dielectric Withstanding Voltage (VAC)	No. of Keyway Orientations	Wire Sealing (mm)		Temperature (°C)*	
							Min.	Max.	Min.	Max.
4	24	01	3	500	1000	6	0.56	1.02	-55	+170

* The upper limit is the maximum internal hot-spot temperature resulting from the combination of the ambient temperature and heating due to current. Contact Technical Support for more detail of specific products to meet your sealed electrical connection requirements.

CONTACTS & TOOLING PART NUMBERS

Contact Size	Socket	Pin	PCB Socket	PCB Pin	Filler Plug	Ins/Ext Tool	Crimp Tool	Socket Positioner	Pin Positioner
24	612879-99	612876-99	611292	611661	600300-24	605837	M22520/2-01	605840	605839

ORDERING INFORMATION

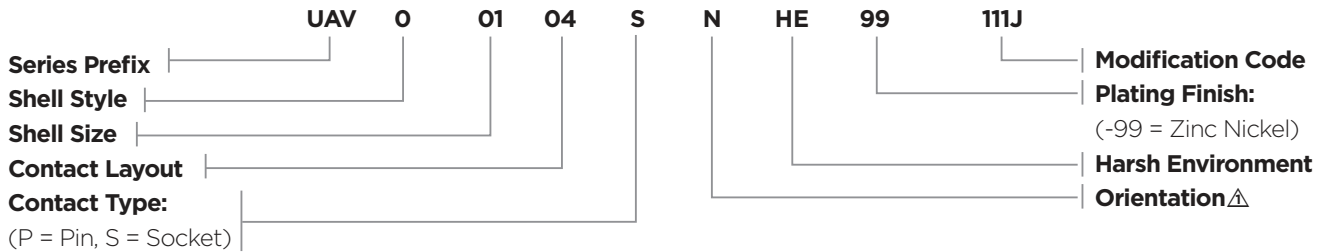

Pro Cap 4 Way Plug

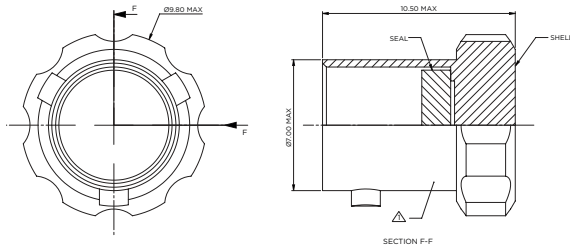

Pro Cap 4 Way Receptacle

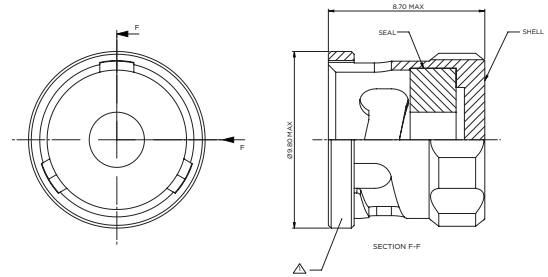

ACCESSORIES PART NUMBERS

Part Number	
Nut Plate	Gasket
ATM396-1	GV-1

	Boot Information	
	Straight	90 degree
Raychem	203W301-25-G02	223W601

Pro Cap	
Socket	Pin
611292	611661

Wildcat UAV Micro Xtra^{LITE} HE 3 Way Connector

Ultra compact design (Size O2 shell)

- Minimum space envelope
- 3 contacts Size #22
- PCB option
- Smaller and lighter than Wildcat UAV Ultra^{LITE} (UAVU) series connectors

Easy installation

- Positive locking coupling mechanism
- Suitable for blind mating
- Scoop proof interface
- Boot termination feature

Built to withstand harsh environments

- Conductive black zinc nickel finish
- Interfacial wire sealing
- Bonded and sealed insert to help prevent moisture ingress

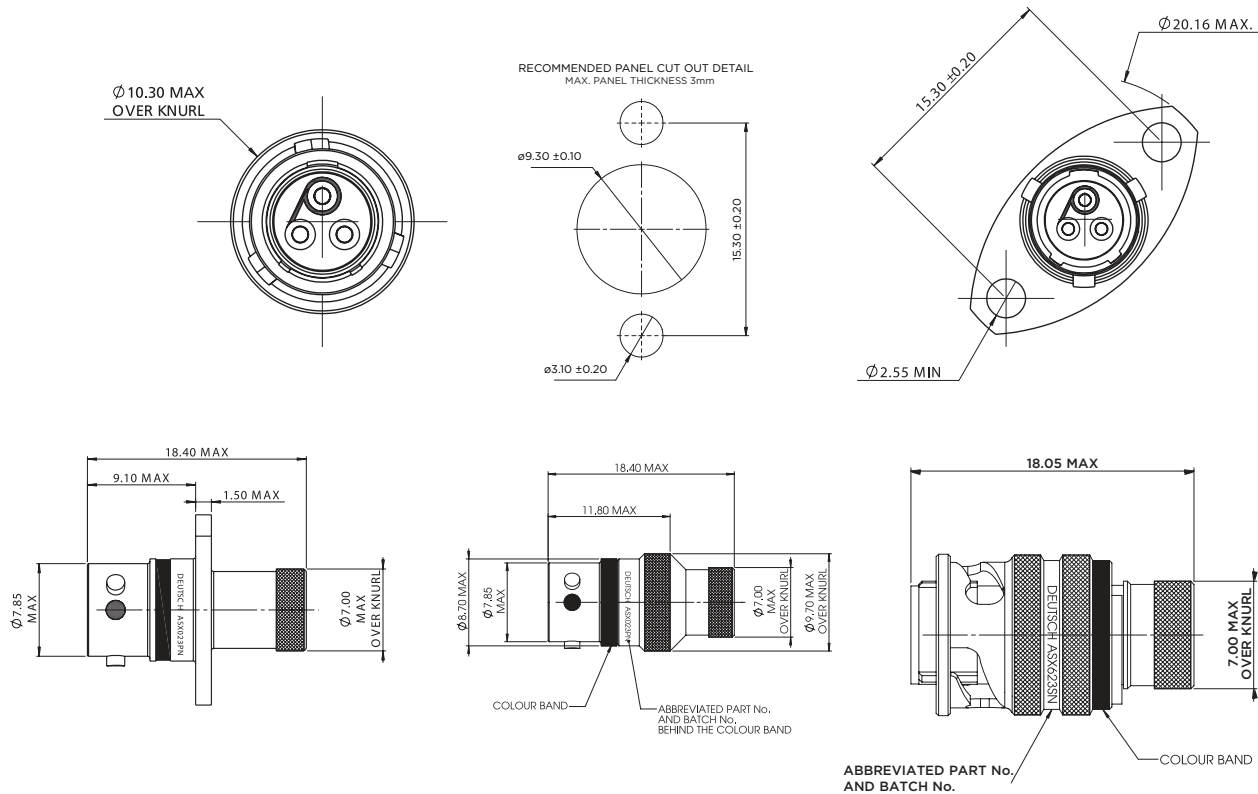

All dimensions are in mm unless otherwise stated.

Wildcat UAV Micro Xtra^{LITE} HE 3 Way Connector (continued)

GENERAL SPECIFICATION

No. of Ways	Contact Size	Shell Size	Max. Current (Amps)	Durability (cycles of engagement & disengagement)	Dielectric Withstanding Voltage (VAC)	No. of Keyway Orientations	Wire Sealing (mm)		Temperature (°C)*	
							Min.	Max.	Min.	Max.
3	22	02	5	500	1500	6	0.76	1.37	-55	+170

* The upper limit is the maximum internal hot-spot temperature resulting from the combination of the ambient temperature and heating due to current. Contact Technical Support for more detail of specific products to meet your sealed electrical connection requirements.

CONTACTS & TOOLING PART NUMBERS

Contact Size	Socket	Pin	PCB Socket	PCB Pin	Filler Plug	Ins/Ext Tool	Crimp Tool	Socket Positioner	Pin Positioner
22	604984	604946-31	611282	611254-31	600300-22	M81969/14-01	M22520/2-01	605464	605463

ORDERING INFORMATION

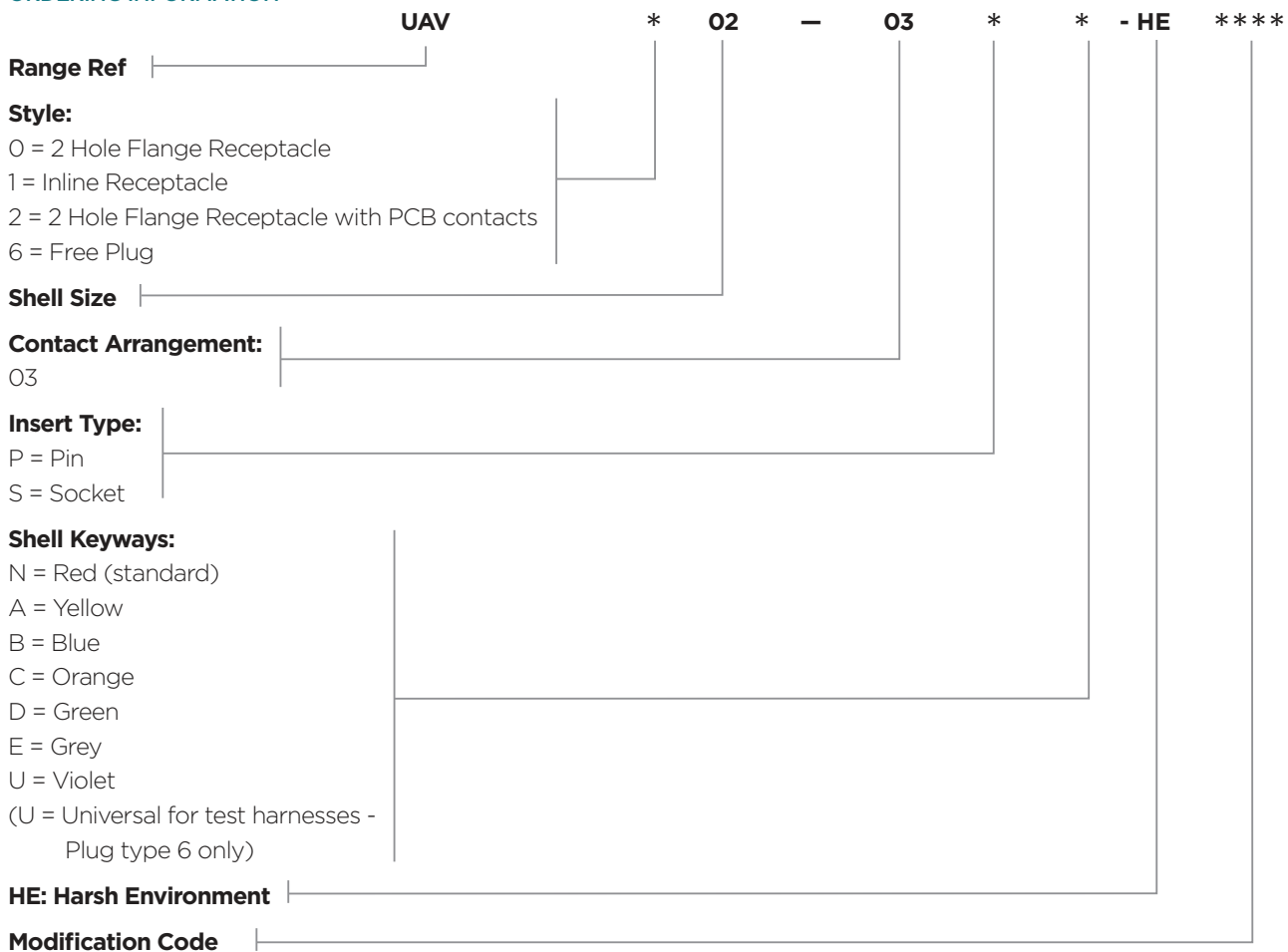

ACCESSORIES PART NUMBERS

Part Number	
Nut Plate	Gasket
ATM396-2	GV-2

	Boot Information	
	Straight	90 degree
Raychem	203W301-25-G02	223W601

Pro Cap	
Receptacle	Plug
611545	611546

Wildcat UAV Micro Xtra^{LITE} HE 5 Way Connector



Ultra compact design (size O2 shell)

- Minimum space envelope
- 5 contacts Size #24
- PCB option
- Smaller and lighter than Wildcat UAV Ultra^{LITE} (UAVU) series connectors

Easy installation

- Positive locking coupling mechanism
- Suitable for blind mating
- Scoop proof interface
- Boot termination feature

Built to withstand harsh environments

- Conductive black zinc nickel finish
- Interfacial wire sealing
- Bonded and sealed insert to help prevent moisture ingress

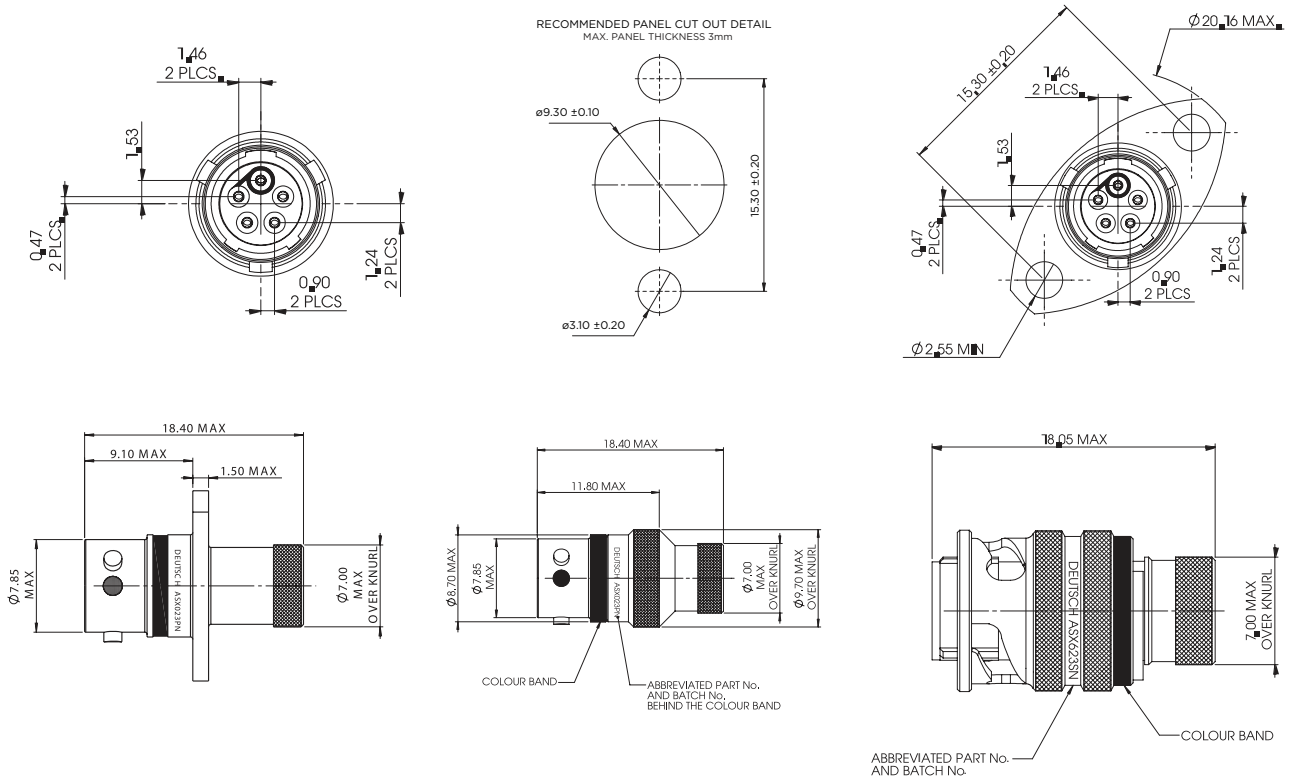

All dimensions are in mm unless otherwise stated.

Wildcat UAV Micro Xtra^{LITE} HE 5 Way Connector (continued)

GENERAL SPECIFICATION

No. of Ways	Contact Size	Shell Size	Max. Current (Amps)	Durability (cycles of engagement & disengagement)	Dielectric Withstanding Voltage (VAC)	No. of Keyway Orientations	Wire Sealing (mm)		Temperature (°C)*	
							Min.	Max.	Min.	Max.
5	24	02	3	500	1000	6	0.56	1.02	-55	+170

* The upper limit is the maximum internal hot-spot temperature resulting from the combination of the ambient temperature and heating due to current. Contact Technical Support for more detail of specific products to meet your sealed electrical connection requirements.

CONTACTS & TOOLING PART NUMBERS

Contact Size	Socket	Pin	PCB Socket	PCB Pin	Filler Plug	Ins/Ext Tool	Crimp Tool	Socket Positioner	Pin Positioner
24	605704	605705-31	611292	611661-31	600300-24	605837	M22520/2-01	605840	605839

ORDERING INFORMATION

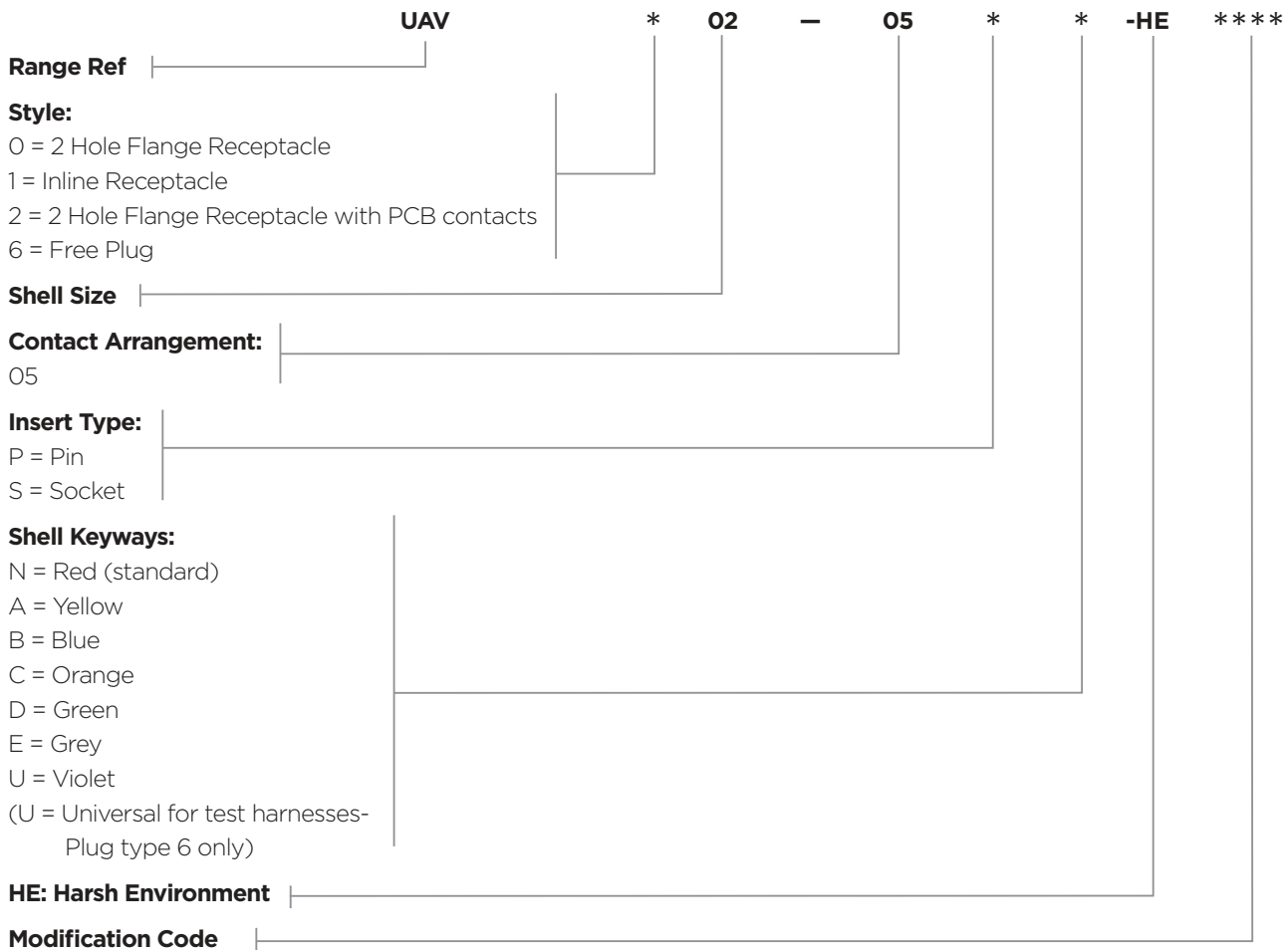

ACCESSORIES PART NUMBERS

Part Number	
Nut Plate	Gasket
ATM396-2	GV-2

	Boot Information	
	Straight	90 degree
Raychem	203W301-25-G02	223W601

Pro Cap	
Receptacle	Plug
611545	611546

Wildcat UAV Micro Xtra^{LITE} HE 6 Way Connector



Ultra compact design (size 02 shell)

- Minimum space envelope
- 6 contacts Size #24
- PCB option
- Smaller and lighter than Wildcat UAV Ultra^{LITE} (UAVU) series connectors

Easy installation

- Positive locking coupling mechanism
- Suitable for blind mating
- Scoop proof interface
- Boot termination feature

Built to withstand harsh environments

- Conductive black zinc nickel finish
- Interfacial wire sealing
- Gold-plated crimp contacts
- Bonded and sealed insert to help prevent moisture ingress

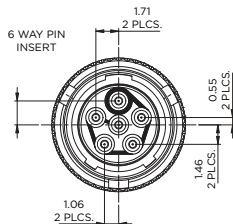

RECOMMENDED PANEL CUT OUT DETAIL
MAX. PANEL THICKNESS 3mm

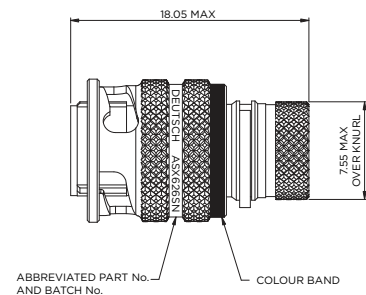
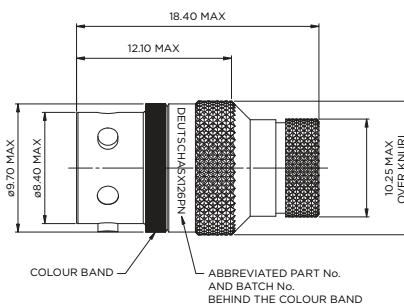
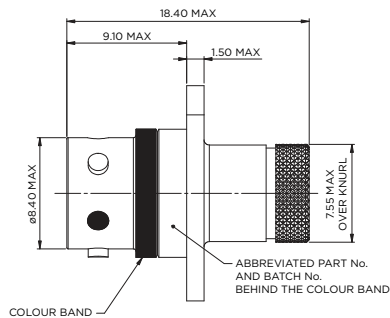
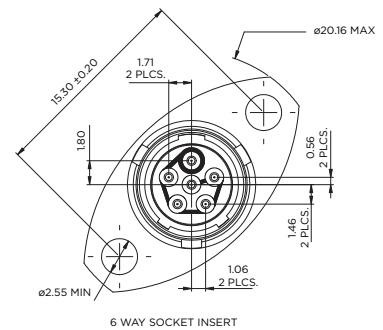
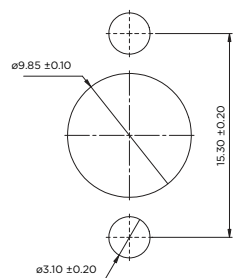

All dimensions are in mm unless otherwise stated.

Wildcat UAV Micro Xtra^{LITE} HE 6 Way Connector (continued)

GENERAL SPECIFICATION

No. of Ways	Contact Size	Shell Size	Max. Current (Amps)	Durability (cycles of engagement & disengagement)	Dielectric Withstanding Voltage (VAC)**	No. of Keyway Orientations	Wire Sealing (mm)		Temperature (°C)*	
							Min.	Max.	Min.	Max.
6	24	02	3	500	1000	6	0.56	1.02	-55	+170

* The upper limit is the maximum internal hot-spot temperature resulting from the combination of the ambient temperature and heating due to current.

** Current leakage less than 2 milliAmps at (VAC)

CONTACTS & TOOLING PART NUMBERS

Contact Size	Socket	Pin	PCB Socket	PCB Pin	Filler Plug	Ins/Ext Tool	Crimp Tool	Socket Positioner	Pin Positioner
24	605704	605705-31	611292	611661-31	600300-24	605837	M22520/2-01	605840	605839

ORDERING INFORMATION

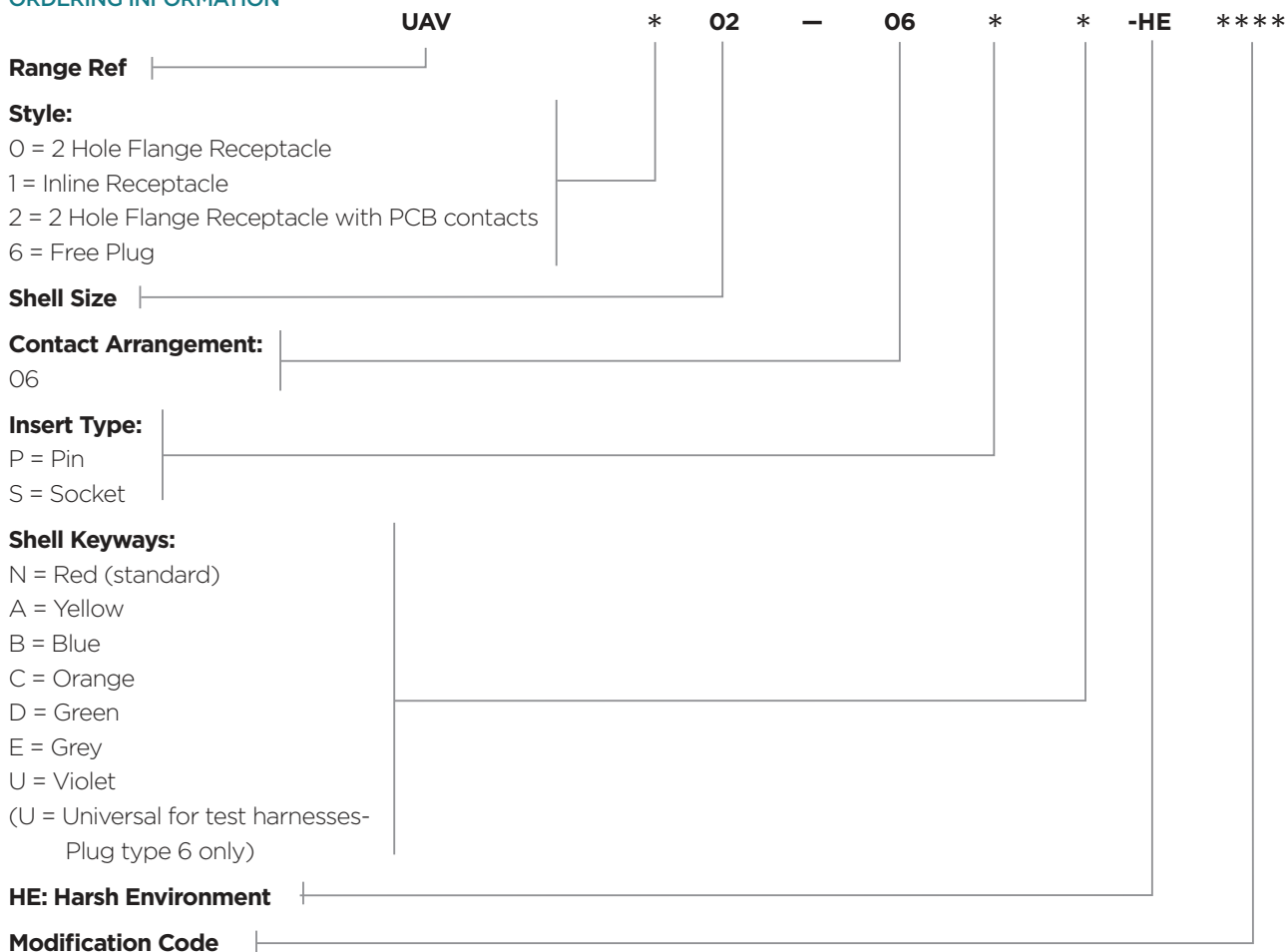

ACCESSORIES PART NUMBERS

Part Number	
Nut Plate	Gasket
ATM396-2	GV-2

	Boot Information	
	Straight	90 degree
Raychem	203W301-25-G02	223W601

Pro Cap	
Receptacle	Plug
611636	611637

Wildcat UAV Micro^{LITE} HE (UAVL) Series Connectors



Compact design (size 06 shell)

- Designed for sensor applications
- 5 contacts Size #23
- PCB option

Easy installation

- Positive locking coupling mechanism
- Suitable for blind mating
- Scoop proof interface
- Boot termination feature

Built to withstand harsh environments

- Conductive black zinc nickel finish
- Interfacial wire sealing
- Bonded and sealed insert to help prevent moisture ingress

PLUG - TYPE 6

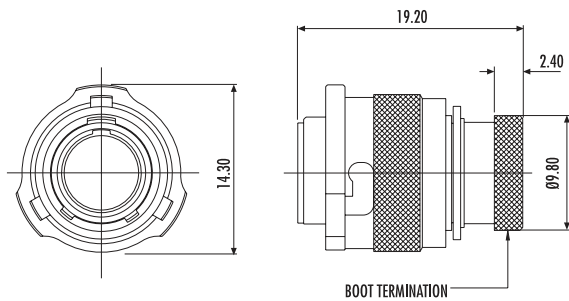

INLINE RECEPTACLE - TYPE 1

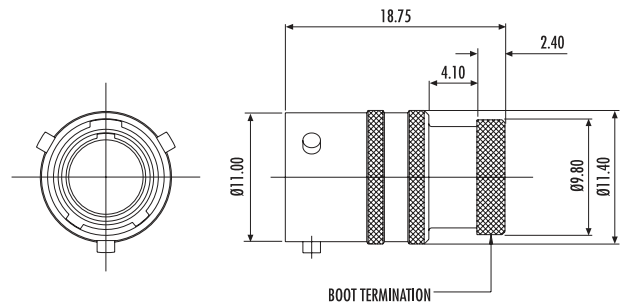

RECEPTACLE - TYPE 0

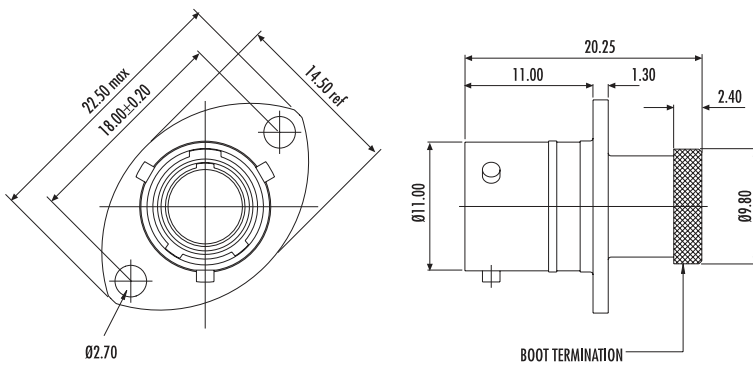

PANEL CUT-OUT DETAIL

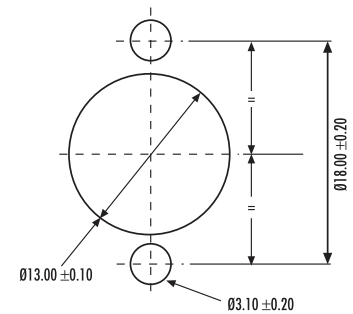

All dimensions are in mm unless otherwise stated.

Wildcat UAV Double Density (UAVDD) Series Connectors



Next generation connector – high density and high performance 8 shell sizes

- Allows for a saving of 2 shell sizes relative to standard planforms
- Very lightweight
- Almost double the number of contacts compared with the standard range equivalent shell size
- Integral screen

Built to withstand harsh environments

- Conductive black zinc nickel finish
- Interfacial wire sealing
- Bonded and sealed insert to help prevent moisture ingress

9-way connector dimensions - For other dimensions, refer to pages 8 to 13

PLUG - TYPE 6

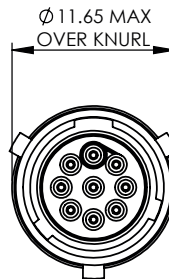
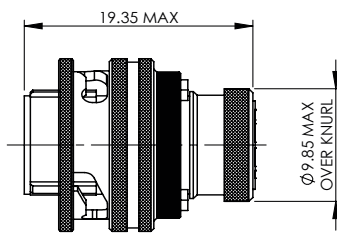
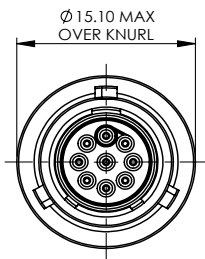

INLINE RECEPTACLE - TYPE 1

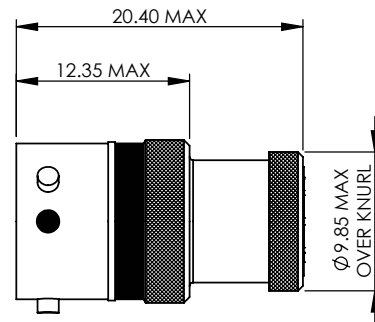

RECEPTACLE - TYPE 0

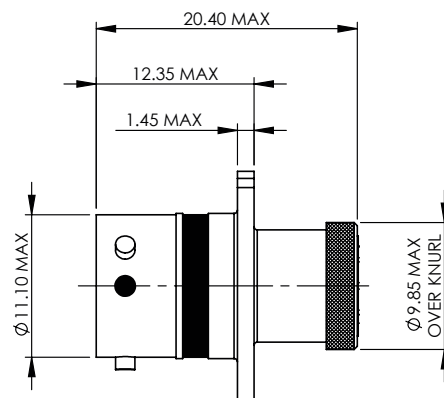
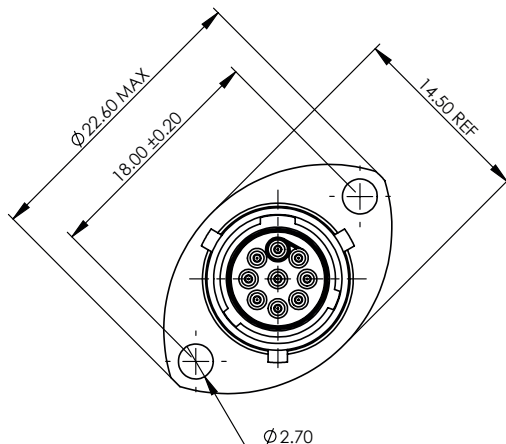

All dimensions are in mm unless otherwise stated.

Wildcat UAV Standard Series Connectors



Large application choices

- Filter, hermetic & fiber optic options available
Shell sizes 08 - 24
- Intermateable with existing LN29729 (Mil-C 38999 Series 1.5) and Pan 6433-2 style connectors
- High density arrangements

Built to withstand harsh environments

- Conductive black zinc nickel finish
- Interfacial wire sealing
- Bonded and sealed insert to help prevent moisture ingress

GENERAL SPECIFICATION

Contact Size	Shell Size	Max. Current (Amps)	Durability (cycles of engagement & disengagement)	No. of Keyway Orientations	Wire Sealing (mm)		Temperature (°C)*	
					Min.	Max.	Min.	Max.
22	08 to 24	5	500	5 only 3 for shell size 8	0.76	1.37	-55	+175
20	see below	7.5			1.02	2.11		
16		20			1.65	2.77		

*The upper limit is the maximum internal hot-spot temperature resulting from the combination of the ambient temperature and heating due to current.

Shell Size	Contact Arrangement	Number of Contacts			Rating **
		Size 22 D	Size 20	Size 16	
08	-98	6	3		I
08	-35				M
10	-98	13	6		I
10	-35				M
10	-02			2	I
10	-03			3	I
12	-04	22		4	I
12	-98			10	I
12	-35				M
14	-97	37	8	4	I
14	-19			19	I
14	-35				M
16	-08	55		8	I
16	-26			26	I
16	-35				M

Shell Size	Contact Arrangement	Number of Contacts				Rating **
		Size 22 D	Size 20	Size 16	Size 12	
18	-32	66	32			I
18	-35					M
20	-16	79		16		I
20	-39			37	2	I
20	-41			41		I
20	-35					M
22	-21	100		21		I
22	-55			55		I
22	-35					M
24	-19	128		29	19	I
24	-29			61		I
24	-61					I
24	-35					M

**Ratings M&I define Dielectric Withstand Voltage ratings as follows:
M = 1300 volts rms, I = 1800 volts rms, current leakage less than 2 milliAmps.

Please note: The contact/insert arrangements shown above are standard layouts. Other combinations of shell sizes and insert arrangements may be available.

For details contact the TE Technical Support.

CONTACTS & TOOLING PART NUMBERS

Contact Size	Socket	Pin	Filler Plug	Ins/Ext Tool	Crimp Tool	Socket Positioner	Pin Positioner
22	38943-22	38941-22	600300-22	M81969/14-01	M22520/2-01	M22520/2-07	M22520/2-09
20	38943-20	38941-20	600300-20	M81969/14-10	M22520/2-01	M22520/2-10	M22520/2-10
16	38943-16	38941-16	600300-16	M81969/14-03	M22520/1-01	M22520/1-04	M22520/1-04

Please note: PCB versions are ordered with UAV2 prefixes and come with contacts.

Wildcat UAV Contact / Insert Arrangements

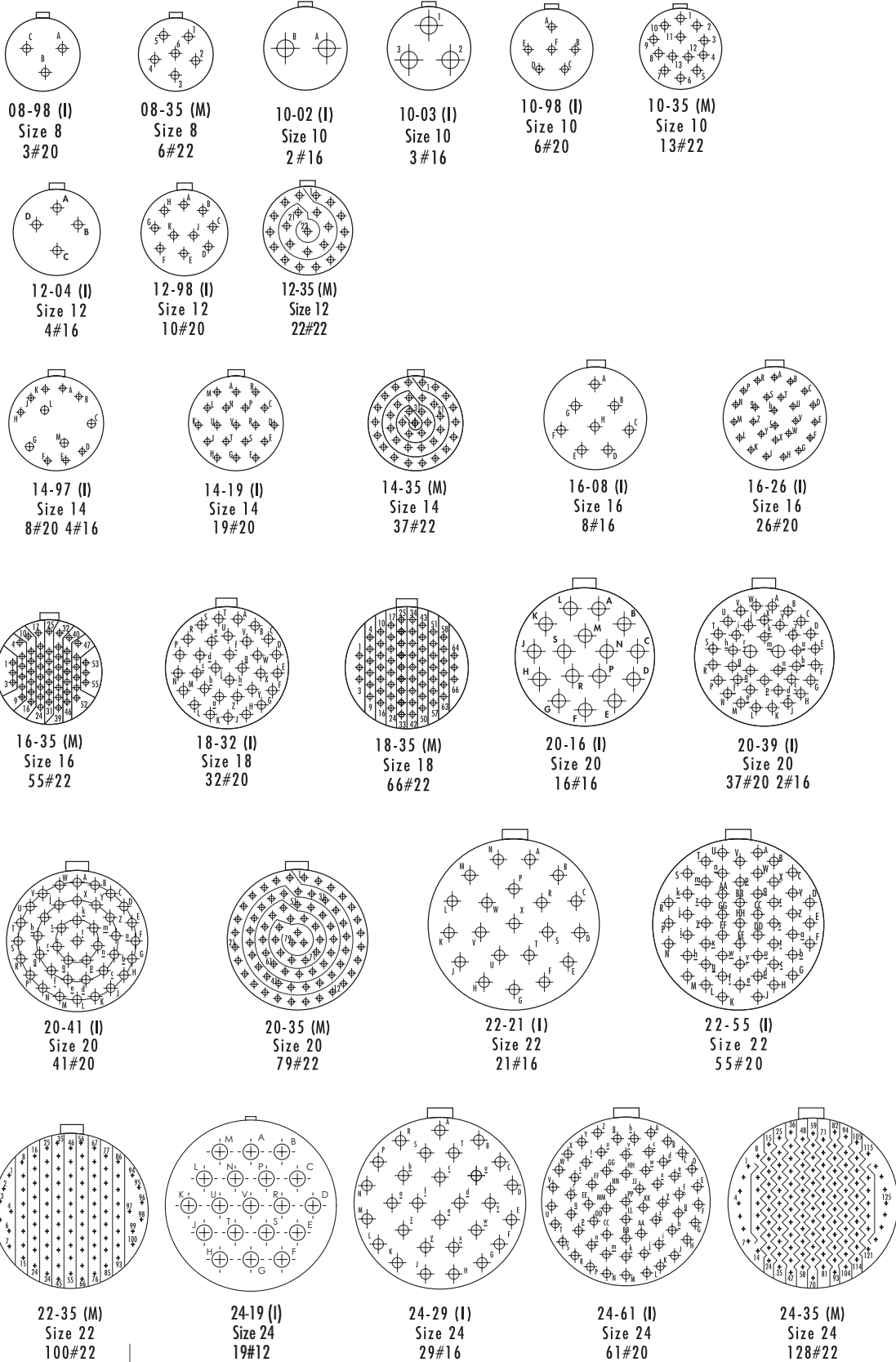

Ratings M&I define Dielectric Withstand Voltage ratings as follows: I = 1800 volts rms, M = 1300 volts rms, current leakage less than 2 milliamps.

Wildcat UAV Standard Series Connectors

PLUG - TYPE 6

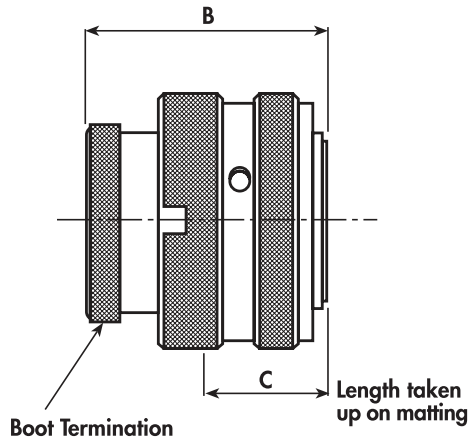

Shell Size	A Max.	B Max.	C Max.
08	17.70	33.50	15.00
10	20.80		
12	25.20		
14	28.40		
16	31.50		
18	34.80		
20	38.20		
22	41.30		
24	44.60		

INLINE RECEPTACLE - TYPE 1

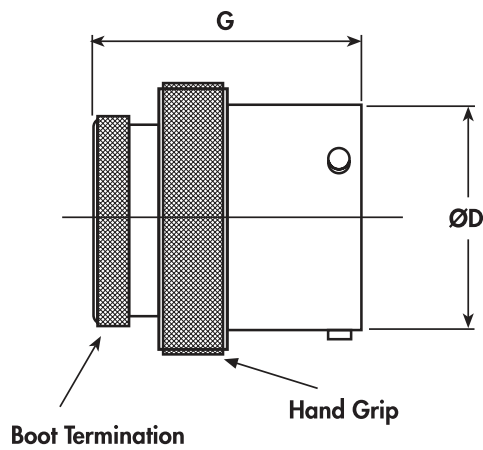

Shell Size	A Max.	D +0 -0.13	G Max.
08	17.70	12.00	33.50
10	20.80	15.00	
12	25.20	19.05	
14	28.40	22.22	
16	31.50	25.40	
18	34.80	28.57	
20	38.20	31.75	
22	41.30	34.92	
24	44.60	38.10	

All dimensions are in mm unless otherwise stated.

Wildcat UAV Standard Series Connectors

RECEPTACLE - TYPE O

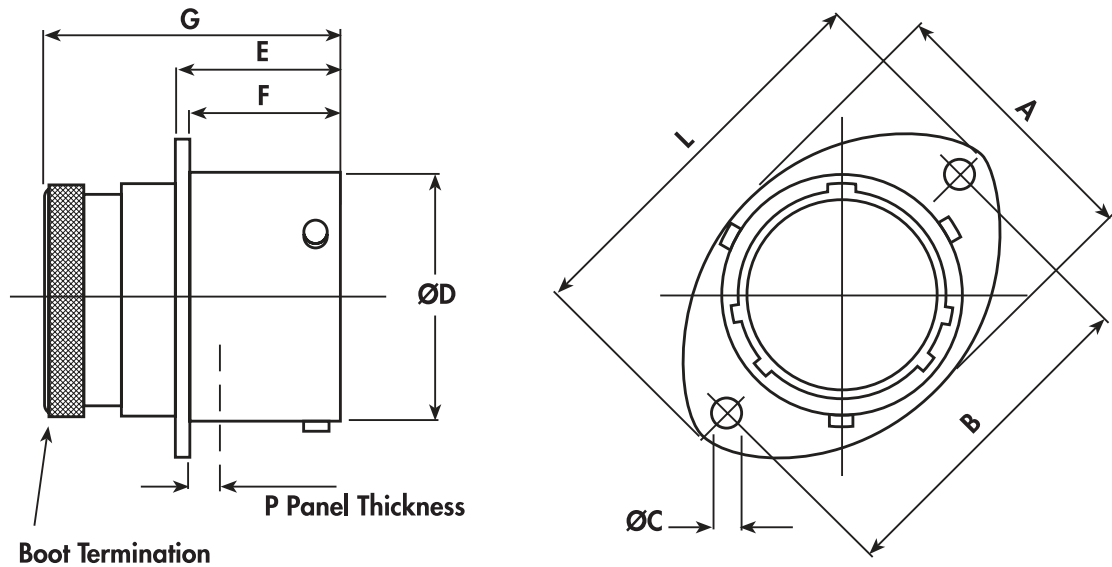

Shell Size	A REF	B ± 0.2	C +0.1 -0	D +0 -0.13	E +0.15 -0	F +0 -0.13	G Max.	L Max.	P Max.
08	16.50	21.35	3.20	12.00	17.21	16.05	33.50	27.20	3.00
10	19.50	25.90		15.00				32.00	
12	24.00	29.10		19.05				35.20	
14	27.00	32.50		22.22				38.40	
16	30.30	34.80		25.40				41.00	
18	33.70	38.20		28.57				44.70	
20	37.00	41.60		31.75				47.90	
22	40.00	44.95	34.92	51.10					
24	43.30	49.35	3.70	38.10			55.80	2.26	

PANEL CUT-OUT DETAIL

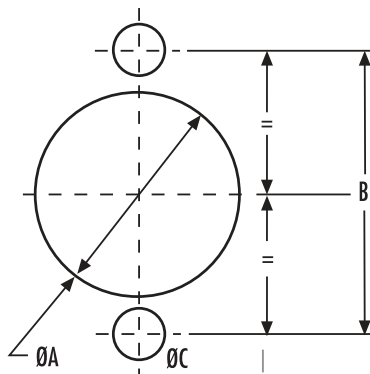

Shell Size	A ±0.10	B ±0.20	C ±0.20
08	14.50	21.40	3.6
10	17.40	25.90	
12	21.90	29.10	
14	25.00	32.50	
16	28.20	34.80	
18	31.40	38.20	
20	34.60	41.60	
22	37.80	44.90	
24	41.00	49.30	4.10

All dimensions are in mm unless otherwise stated.

Wildcat UAV Standard Series Connectors

PCB BOX MOUNTING RECEPTACLE - TYPE 2

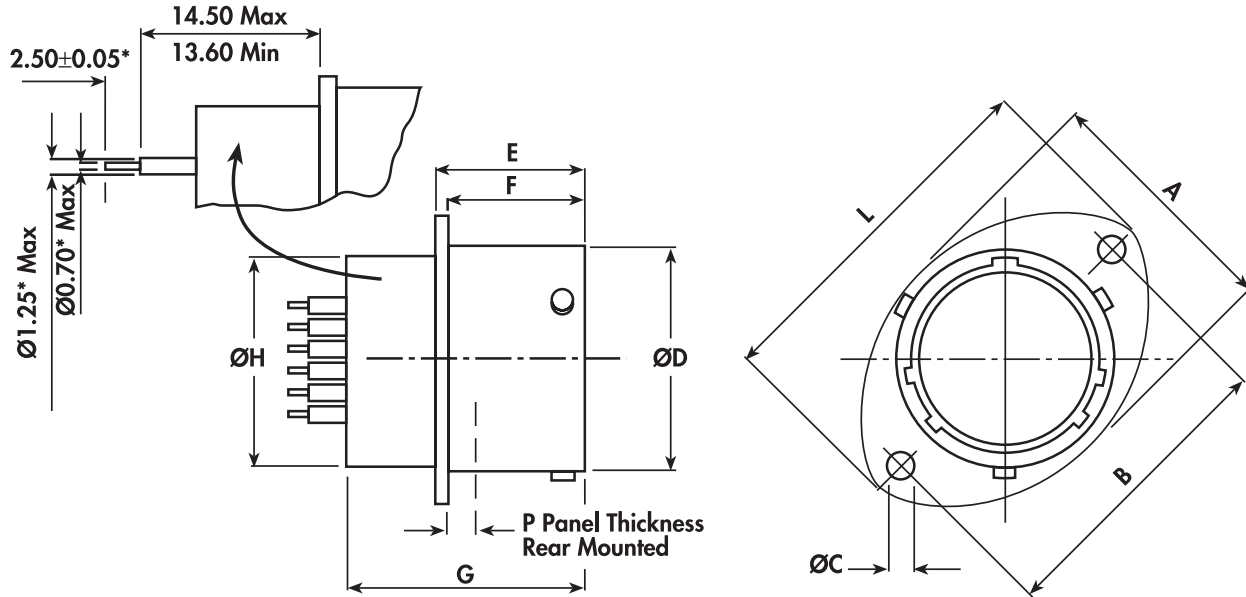

*Dimensions for 20 and 22 contacts shown are for standard parts. Other PCB contacts are available.

Shell Size	A REF	B ± 0.2	C +0.1 -0	D +0 -0.13	E +0.15 -0	F +0 -0.13	G Max.	H Max.	L Max.	P Max.
08	16.50	21.40	3.7	12.00	17.21	16.05	27.65	11.10	27.20	3.00
10	19.50	25.90		15.00				14.27	32.00	
12	24.00	29.10		19.05				17.44	35.20	
14	27.00	32.50		22.22				20.60	38.40	
16	30.30	34.80		25.40				23.77	41.00	
18	33.70	38.20		28.57				26.94	44.70	
20	37.00	41.60		31.75				30.11	47.90	
22	40.00	44.95		34.92		33.29	51.10			
24	43.30	49.35	38.10	36.46	55.80	2.26				

All dimensions are in mm unless otherwise stated.

Wildcat UAV Standard Series Connectors

ORDERING INFORMATION

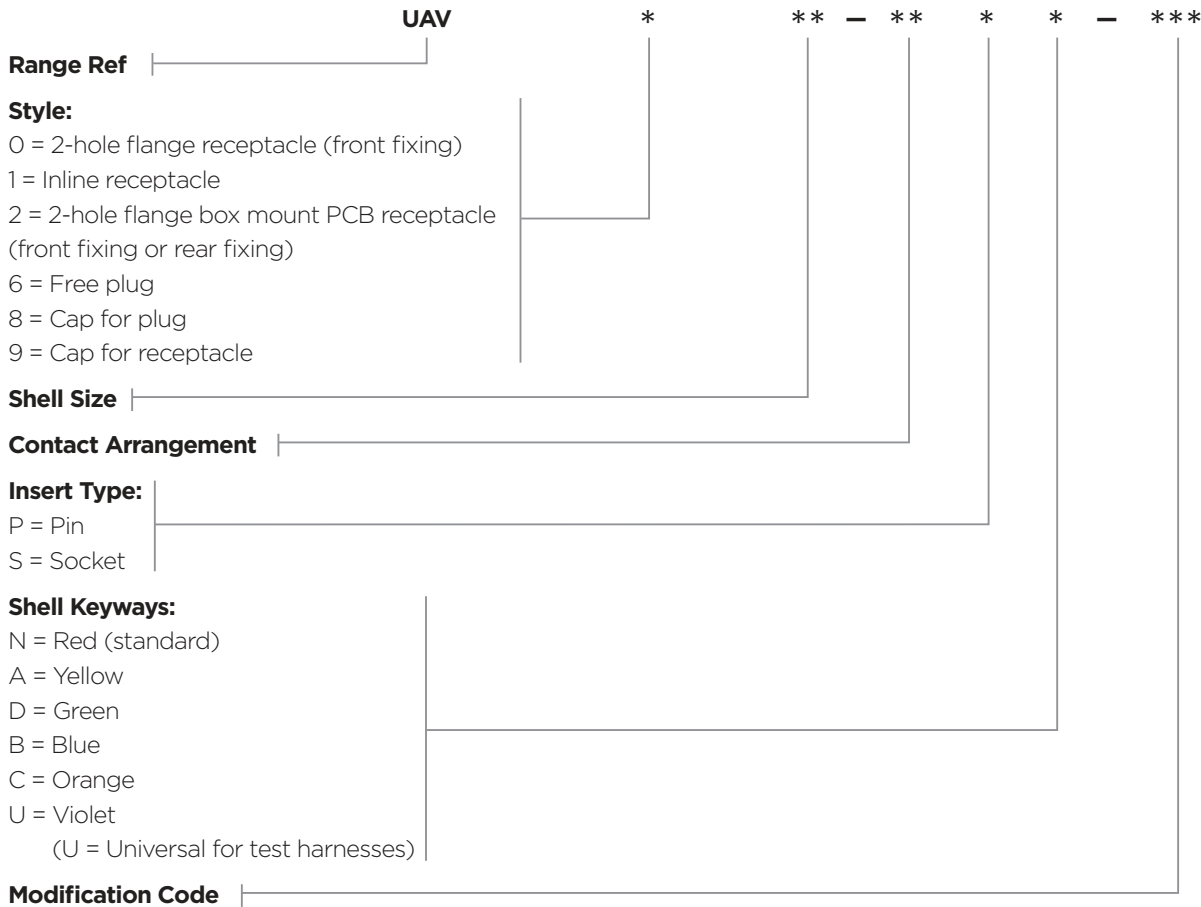

Please note: The size 8 shell is only available in keyways A, D and N.

ACCESSORIES PART NUMBERS

Shell Size	Nut Plate	Gasket
08	ATM396 -8	GV-08
10	ATM396 -10	GV-10
12	ATM396 -12	GV-12
14	ATM396 -14	GV-14
16	ATM396 -16	GV-16
18	ATM396 -18	GV-18
20	ATM396 -20	GV-20
22	ATM396 -22	GV-22
24	ATM396 -24	GV-24

BOOT TERMINATION DETAIL

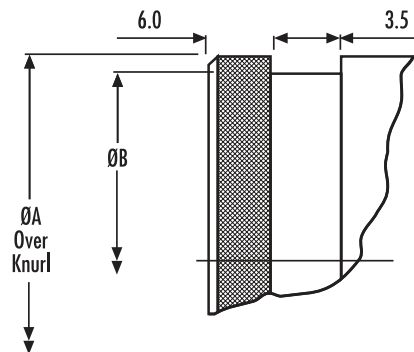

Shell Size	A ± 0.10	B ± 0.05
08	11.20	10.00
10	14.22	12.95
12	17.39	16.15
14	20.55	19.15
16	23.72	23.35
18	26.89	25.35
20	30.06	28.50
22	33.24	31.70
24	36.41	34.85

All dimensions are in mm unless otherwise stated.

Half Flange

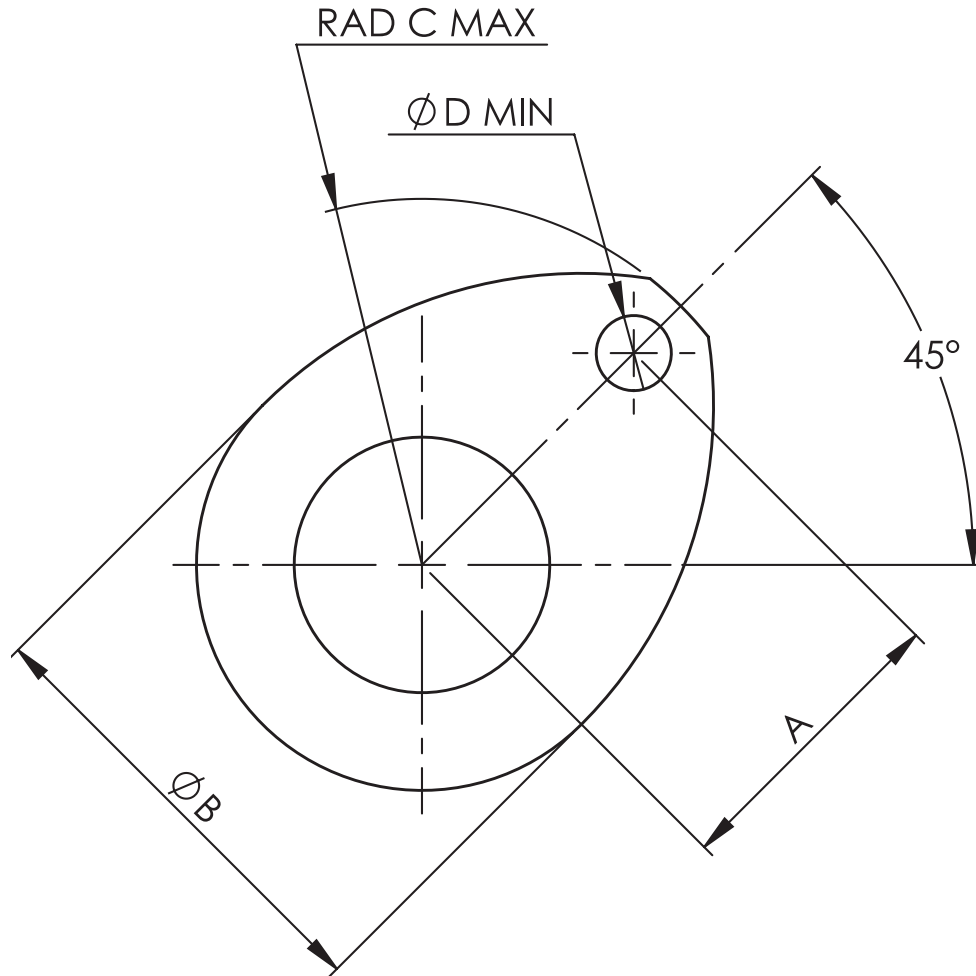

Shell Size	A	ØB Max	Rad C Max	ØD Min
01	6.00	8.80	8.25	2.20
02 (UAV 3 & 5 Way)	7.65	10.08	10.08	2.55
02 (UAV 6 Way)	7.65	10.65	10.08	2.55
06	9.10	14.66	11.25	2.55
08	10.78	16.66	13.60	3.20
10	13.05	19.66	16.00	3.20
12	14.65	24.16	17.60	3.20

Unless otherwise stated, dimensions are in mm.



Other Related Products



Wildcat UAV Micro HE Hermetic Series Connectors

- Filtered Hermetic option also available
- Stainless Steel (316) for ease of mounting and corrosion performance
- Titanium versions for light weight applications also available
- Glass seal can withstand pressure differentials of 1000 psi without loss of electrical performance or fluid leakage



Wildcat UAV Micro Hermetic (Jam-Nut) Series Connectors

- Jam-nut fixing
- Enlarged backshell for easier contact soldering
- Fuel immersible specification O-ring for enhanced fluid resistance
- Glass seal can withstand pressure differentials of 1000 psi without loss of electrical performance or fluid leakage
- Fully intermateable with UAV Micro HE connector and Micro^{LITE} connector



Wildcat UAV Hermetic Fuel Tank Series Connectors

- Fuel tank applications
- Glass to metal hermetic sealing
- Fuel-immersible specification o-ring
- High standard of sealing between connector and bulkhead



Wildcat UAV Co-ax Series

- Ultra compact and light weight design (size 3 shell)
- Single co-axial contact and gold-plated crimp contacts
- Positive locking coupling mechanism with 2 keyway orientations and boot termination feature
- Designed for RG316 cable



Clinchnut Wildcat UAV Series

- A replacement for nutplates
- Available for PCB and flange mounted versions
- Time-saving option
- Available across the range of Wildcat UAV connectors



Low Profile PCB Series

- Specifically designed for control box applications
- Only 3 mm length behind the flange
- Reduces unnecessary space within boxes
- Allows for space and weight saving of control boxes

Contact TE for related product information.

Other Related Products *(continued)*



Wildcat UAV3 Through Bulkhead Series

- Military proven design with scoop-proof interface
- Positive locking coupling mechanism; thermal cycle tested
- Environmentally sealed to IP67; gold plated crimp contacts
- Fully intermateable with Wildcat UAV range of products
- 4 hole mounting style

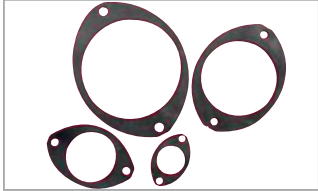

Termination Boots and Accessories

Gaskets

- Designed specifically for Wildcat UAV flanged connectors
- Available from size 02 through to 24 shells
- Constructed from fluoroelastomer polymer
- Assist in sealing connectors to the mounting point



Nut Plates

- Available for all Wildcat UAV two-hole flange mounted connector receptacles
- Designed to simplify connector-to-bulkhead assembly
- Eliminate the need to position loose nuts and washers
- Anti-vibration and make assembly quicker and easier



Braid Termination Systems

Attaching braid to the back of a high performance connector can be done in a number of ways, depending on the environment the connector will be operating in. The standard practice of a metal strap on the braid to fasten it to the groove at the back of the shell is seen as a reliable solution with tooling and straps available from a number of sources.

TE's engineers would suggest TE Connectivity screened backshell options which can be found on-line at www.te.com/usa-en/product-CX6566-000.html.

Contact TE for related product information.

How to Order

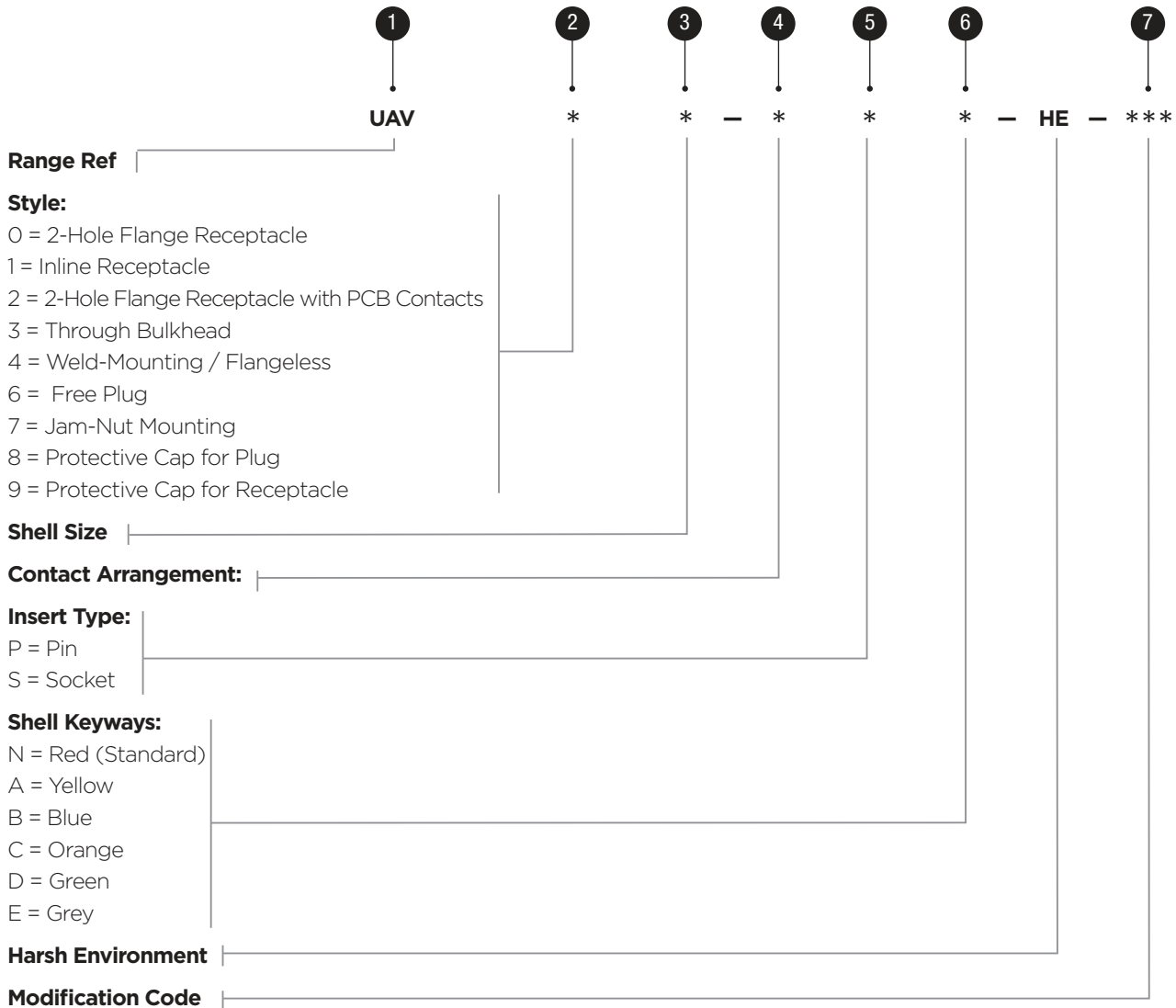

All Wildcat UAV part numbers work to the same principles. The part number is broken down into sections as follows:

- 'UAV' indicates that this is a connector for Autonomous Systems. There may be another letter after UAV - this designates a particular series. For example UAVDD = Double Density.
- The next major element is the connector style.
 0 = 2 hole flanged receptacle
 1 = Inline receptacle
 2 = 2 hole flanged receptacle with fixed PCB contacts
 3 = Through bulkhead
 4 = Weld mounting / flangeless
 6 = Free plug
 7 = Jam-nut mounting
 8 = Protective cap for plug
 9 = Protective cap for receptacle
Please note: not all of these options are available on all products; the relevant product pages will give you this information.
- Relates to the required shell size. This will range from 02 (small) to 24 (large).
- Is the planform detail (number of contacts).
- Indicates the gender of a plug or receptacle. 'P' for pin or 'S' for socket.
- Designates a keyway. Only connectors of the same keyway can mate. The options are: N, A, B, C, D, E or U for universal or no keyway option. The 'U' option should only be selected for test harnesses and not for racing applications.
- After all these elements there may be a 4-character code, which designates a special modification. For instance this can be a special contact length or a non-standard plating finish. For more information on modification codes please visit te.com/support to chat with a Product Information Specialist.

Reference Guide

CONTACT TYPE

Contact Size	Part No.	P/S	Wire Range	Color Band	Max. Current	Crimp tool	Positioner		Plastic Tools Insert/Removal
Size 24 UAVDD excluding 9-way	605719-31	P	24-30	None	3 Amps	M22520/2-01	610286	P	605837 Orange/White
	605721	s					610287	s	
Size 24 UAVDD 9 way, UAV 5/6, UAVU 5 way	605705-31	P	24-30	None	3 Amps	M22520/2-01	605839	P	605837 Orange/White
	605704	s					605840	s	
Size 23	604927-31	P	22-28	None	3 Amps	M22520/2-01	604972	P	M81969/14-01 Green/White
	604935	s					604973	s	
Size 22	38941-22	P	22-26	Orange, Blue, Black	5 Amps	M22520/2-01	M22520/2-09	P	M81969/14-01 Green/White
	38943-22	s		Orange, Yellow, Grey			M22520/2-07	s	
Size 20	38941-20	P	20-24	Orange, Blue, Orange	7.5 Amps	M22520/2-01	M22520/2-10	P	M81969/14-10 Red/Orange
	38943-20	s		Orange, Green, Brown			M22520/2-10	s	
Size 16	38941-16	P	16-20	Orange, Blue, Yellow	20 Amps	M22520/1-01	M22520/1-04	P	M81969/14-03 Blue/White
	38943-16	s		Orange, Green, Red			M22520/1-04	s	
Size 12	38941-12	P	12-14	Orange, Blue, Green	23 Amps	M22520/1-01	M22520/1-04	P	M18969/14-04
	38943-12	s		Orange, Green, Orange			M22520/1-04	s	
Size 22 UAV 3-Way	604946-31	P	22-28	None	5 Amps	M22520/2-01	605463	P	M81969/14-01 Green/White
	604984	s					605464	s	

BOOT INFORMATION

SHELL SIZE	STRAIGHT BOOT	90 DEGREE BOOT
	RAYCHEM	RAYCHEM
UAV (Size 02)	203W301-25-G02	223W601
06	204W221	224W221
08	202K121	222K121
10	202K132	222K132
12	202K142	222K142
14	202K142	222K142
16	202K153	222K152
18	202K153	222K152
20	202K163	222K163
22	202K163	222K163
24	202K174	222K174

FILLER PLUGS

CONTACT SIZE	PART NUMBER
24	600300-24
23	600300-22
22	600300-22
20	600300-20
16	600300-16
12	600300-12

Reference Guide (continued)

Accessories

Shell Size	Nutplate	Gasket	Plug/Receptacle	ProtectiveCap
02 (UAV 3/5)	ATM396-2 M2	GV-2	Plug	611546
			Receptacle	611545
02 (UAV 6 only)	ATM396-2 M2	GV-2	Plug	611637
			Receptacle	611636
03 (UAVU 3/5)	ATM396-4 M2	GV-3	Plug	605687
			Receptacle	605684
06 (UAVL)	ATM396-6 M2.5	GV-6	Plug	604027
			Receptacle	604029
07 (Mini)	ATM396-7 M3	GV-7	Plug	603596-07-99
			Receptacle	603597-07-99
08	ATM396-8 M3	GV-8	Plug	603596-08-99
			Receptacle	603597-08-99
10	ATM396-10 M3	GV-10	Plug	603596-10-99
			Receptacle	603597-10-99
12	ATM396-12 M3	GV-12	Plug	603596-12-99
			Receptacle	603597-12-99
14	ATM396-14 M3	GV-14	Plug	603596-14-99
			Receptacle	603597-14-99
16	ATM396-16 M3	GV-16	Plug	603596-16-99
			Receptacle	603597-16-99
18	ATM396-18 M3	GV-18	Plug	603596-18-99
			Receptacle	603597-18-99
20	ATM396-20 M3	GV-20	Plug	603596-20-99
			Receptacle	603597-20-99
22	ATM396-22 M3	GV-22	Plug	603596-22-99
			Receptacle	603597-22-99
24	ATM396-24 M3	GV-24	Plug	603596-24-99
			Receptacle	603597-24-99

WIRE SIZES AND DIMENSIONS

Size		Finished Wire Dimensions			
Contact Size	Wire Size (AWG)	Conductor		Insulation	
		Min.	Max.	Min.	Max.
24	30, 28, 26, 24	0.254 mm 0.010 in	0.511 mm 0.02 in	0.56 mm 0.22 in	1.02 mm 0.040 in
23	28, 26, 24, 22	0.321 mm .012 in	0.790 mm .031 in	0.60 mm .023 in	1.37 mm .054 in
22	26, 24, 22	0.405 mm .015 in	0.790 mm .031 in	0.76 mm .030 in	1.37 mm .054 in
20	24, 22, 20	0.511 mm .02 in	0.970 mm .038 in	1.02 mm .040 in	2.11 mm .083 in
16	20, 18, 16	0.812 mm .031 in	1.530 mm .060 in	1.65 mm .065 in	2.77 mm .109 in
12	14, 12	1.62 mm (0.064 in)	2.05 mm (0.08 in)	2.46 mm (0.097 in)	3.61 mm (0.142 in)

TORQUE (IN-LBS)

Thread Size	Min	Max
M2	0.18	1.77
M2.5	0.23	3.8
M3	0.5	5

Wire Preparation



Not the best way to strip insulation. Pliers may remove the insulation, but are also likely to break and remove strands of the wire too.

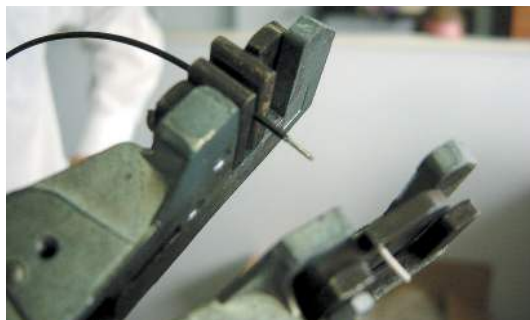

Wire stripping with a recommended tool will allow the insulation to be removed accurately without damaging the wires.

When the insulation has been removed NEVER twist the strands of wire. Doing so changes the diameter of the wire which may mean it cannot easily enter the contact bucket.

This practice also causes different strands to be under different stress levels; thus the crimp will never have an equal finish.

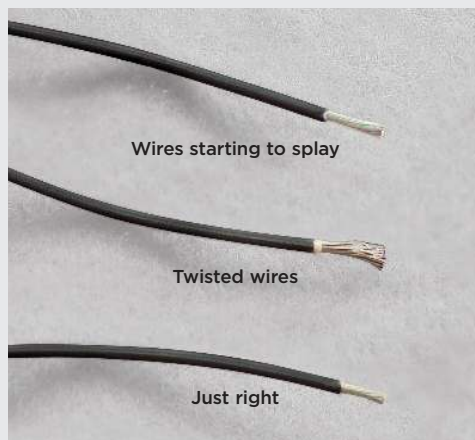

A fundamental aspect of preparing a good crimp is the work required prior to the removal of the connector from its bag. The wire must be prepared correctly in order to ensure that the crimp is as secure and efficient as possible.

The first action that must be taken is to cut the wire to the required length. The wire-cutting tool must be sharp enough to create a clean, square cut (i. e. 90 degrees across the wire). If the wire is not cut square, this will leave strands of the conductor at different lengths. If a crimp is attempted with the wire in this condition, not all of the conductor strands will be inserted into the crimp bucket of the contact to a sufficient depth. This could potentially weaken the final crimp. When the wire has been cut correctly, the next step is to strip the insulation. In order to carry out this task correctly, a professional wire-stripping tool is required. There are several on the market, but as is the case with any tool used in harness work, a higher quality tool will result in a higher quality final product.

We recommend a tool with wire gauges that also employs a mechanical action to strip the insulation. Stripping tools that rely on manual strength to strip the insulation can often result in damage to the wire, with one or more of the conductor strands being removed, which is undesirable.



An example of a good crimp showing the exposed wire

There is a degree of flexibility regarding the length of strip required. As a guide, the final product should allow a small (1 mm) length of exposed conductor visible from the back end of the contact when the wire is FULLY inserted into the crimp bucket. This will allow movement of the wire without damaging the crimp. If the insulation is cut too close to the back end of the contact, this could subject the crimp to extra stress.

Suggested Wire Strip Lengths

Exact lengths for wire strips should be included in each harness house's formal technical procedures, but as a general recommendation, no more than 1 mm of the conductor should be left exposed after crimping. If after a 'test insertion' is carried out, more of the conductor is left exposed than is required, then more of the conductor can be trimmed from the end of the wire. Again, a sharp wire-cutting tool should be used in order to ensure that the cut is clean and square.

Contact Type	Suggested Wire Strip Length
ASU #24	3.8 - 4.8 mm
ASU #22	3.8 - 4.8 mm
ASL	3.8 - 4.0 mm
ASC	3.8 - 4.8 mm
ASU Mini #22	3.8 - 4.8 mm
ASU Mini #20	5.6 - 6.6 mm
ASDD 9-Way #24	3.8 - 4.8 mm
ASD #24	3.8 - 4.8 mm
AS #22	3.8 - 4.8 mm
AS #20	5.6 - 6.6 mm
AS #16	5.6 - 6.6 mm
ASHD	15.0 - 16.0 mm

Contact Insertion



1 After a successful crimp, the contact can now be inserted into the connector. Using the insert/extraction tool provided, slide the wire, using your thumb, so that the wire is enclosed by the tool.



2 This image shows the wire successfully held in the tool.

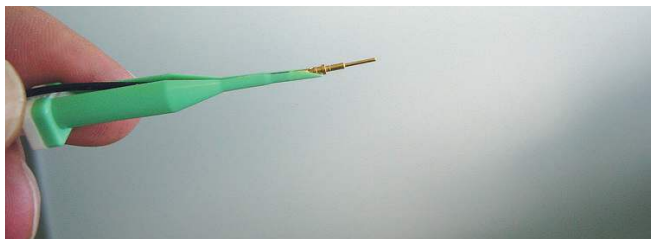

3 After gently pulling the wire through the tool, the contact will now be in position at the end of the tool. The contact should fit securely and the wire should not have any slack.



7 Once the tool has been fully inserted in the back of the connector, there will be a discernable *click* as the shoulder of the contact passes through the tines and locks into position. The tool can then be removed leaving the contact locked into position.

It is recommended either to use a contact retention test tool or give the wire a small tug to ensure the contact is installed correctly.



4 This image shows detail of the tines inside the connector. The process of inserting a contact into the connector will slide the contact into position, allowing the shoulder to pass beyond the tines, which will lock into position behind the shoulder. The insertion end of the tool is molded at an angle to ease the contact into position. The extraction end of the tool is molded with a straight end to *unlock* the tines and allow contact removal.



5 This image shows a contact being dipped in IPA to lubricate the insertion process.



6 Contact being inserted through rear rubber of the connector. Insertion tool should NEVER be rotated, as this will damage the tool and the tines. If the tines get broken the contact may not be retained in the connector.

Contact Extraction



To remove a correctly installed contact, the other end of the tool is used. The extraction end of the tool has a flat aspect to enable all the tines to be unlocked together. The extraction end of the tool is inserted into the rear of the connector until the tines can be felt to unlock. Again, IPA can be used to lubricate the tool. A thumb should then be placed on the wire gripping the wire to the tool. The contact and wire can then be pulled from the back of the connector and a proper extraction can occur.

Connect With Us

We make it easy to connect with our experts and are ready to provide the support you need.

Visit te.com/support to chat with a Product Information Specialist.

te.com/wildcat

TE, TE Connectivity, TE connectivity (logo), and EVERY CONNECTION COUNTS are trademarks owned or licensed by the TE Connectivity plc family of companies. Other product names, logos, and company names mentioned herein may be trademarks of their respective owners.

While TE has made every reasonable effort to ensure the accuracy of the information in this document, TE does not guarantee that it is error-free, nor does TE make any other representation, warranty or guarantee that the information is accurate, correct, reliable or current. TE reserves the right to make any changes to the information contained herein without prior notice. TE Connectivity assumes only those obligations set forth in the terms and conditions for this product and shall in no event be liable for any incidental, indirect, or consequential damages arising out of the sale, resale, use, or misapplication of the product. TE expressly disclaims any implied warranties with respect to the information contained herein, including, but not limited to, implied warranties of merchantability or fitness for a particular purpose. Dimensions, specifications and/or information contained herein are for reference purposes only and are subject to change without notice. Consult TE for the latest dimensions, specifications and/or information. Users of TE Connectivity products must make their own assessment as to whether the respective product is suitable for the respective desired application.

© 2025 TE Connectivity. All Rights Reserved.

2387192-1 07/25

TE Connectivity
Aerospace, Defense & Marine
2900 Fulling Mill Road
Middletown, PA 17057