



Smart Sensors
for a Dynamic Sea

**OCEAN
CONDUCTIVITY
TEMPERATURE
SENSOR FOR
SHALLOW
WATER**

D2 CONDUCTIVITY TEMPERATURE SENSOR



D-2 Inc.'s New Conductivity Temperature (Marine) Sensor, (OC-CT), is a low-cost small footprint sensor for measuring Ocean Salinity (Conductivity) and Ocean Temperature in real time. The sensor operates in the 0-600M depth range providing extremely accurate temperature and salinity data. Perfect for buoys, USV's, and handheld measurements.

Features of the Conductivity Sensor

- Fully self-contained digital data sensor.
- Ultra- Low Power processor, EEPROM Calibration storage.
- 2 Hertz sampling is continuous.
- 600 Meter Max Depth Operation.
- Low Pass Filter of user prescribe cut off can be applied to the data.
- RS-232 Data Output
- Plug and Play Device 8. Extremely small footprint size Features Continued...
- Easy 2-Character Serial Commands allow 'HyperTerminal®' or other simple program data collection
- Sensor calibrated in a computer-controlled bath, using natural seawater; a water sample at each point is compared to IAPSO seawater using a Salinometer.
- MCBH5MSS Connector

Options

- Data Cable 5m
- Data Cable 3m
- Battery Pack OC-BAT-AL
- 0-7 S/M Range

D2 Ocean CT Specifications

- Conductivity Range
- 0 to 60 mS/cm
- Accuracy: 0.02 mS/cm
- Resolution: .005 mS/cm
- Sampling Rate: 2 Hz

Temperature Range: -5 to 40 Deg C

- Accuracy: 0.02 Deg C
- Resolution: .005 Deg C
- Sampling Rate: 2 Hz

Performance

- Stability 0.005 mS/cm per Month
- Resolution 20 Bits
- Sampling 2hz aka 2 Samples/Second
- Supply 5 – 14 VDC
- Power 80 mW @ 5VDC Input
- Communication RS-232
- Baud Rate: 19200 Baud
- Data Format ASCII Units mS/cm, C, IPSS

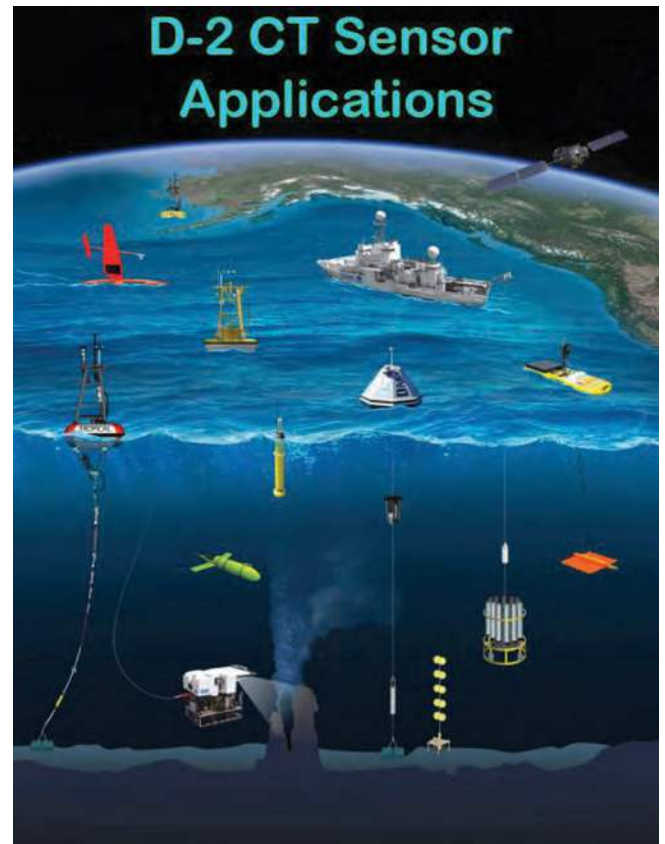

The Ocean CT Sensor provides a low-cost solution to test for Ocean Conductivity aka Salinity and Temperature for the first 600 meters of depth in the Ocean. Extremely small footprint size and low power demand. Ideal for use in Coastal Monitoring and Surface Climate Research studies. These sensors have been deployed on Oceanographic buoy arrays to provide Salinity and Temperature data.

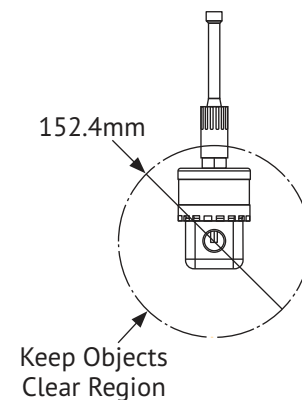
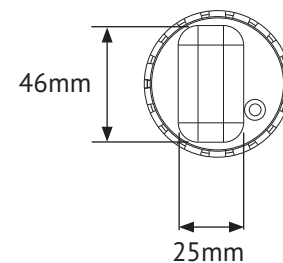
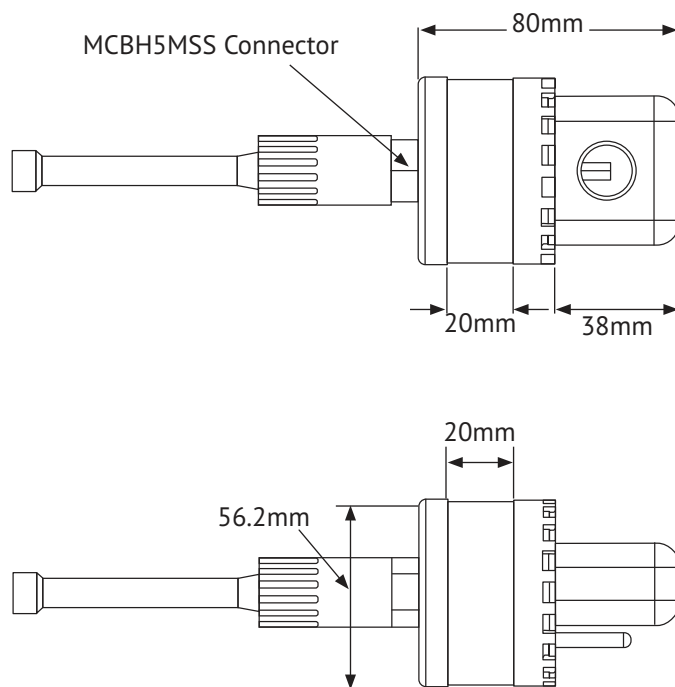



D2 Conductivity-Temperature Sensor

The D-2 Conductivity-Temperature (OC-CT) Sensor is a modular, self-contained instrument that measures conductivity from 0 to 60 mS/cm optionally 0 to 7 S/m, covering the full range of oceanic applications. The sensor is fully electrically isolated from circuitry to eliminate any possibility of noise and corrosion caused by ground loops. Interfacing is also simplified by the industry standard RS-232 data interface, simple two letter commands, and data in standard S/M units. The sensor has no internal temperature compensation requirements, smaller fit residuals, and fast turn-on stabilization.

Because of the D-2 Conductivity-Temperature characteristics, novel new high performance measuring techniques (used in all D-2's CTD instruments), are coupled with a low volume to cross sectional area free flushing inductively coupled conductivity sensor we can sound long term deployments in low flow areas. The D-2 Conductivity-Temperature sensor is ideally suited for obtaining data with serial data input direct logging systems. Sensor can be easily clean post deployment as the center of the conductivity sensor is a quartz glass polished tube.

Part Number: OC-CT-DL-1-000-0

OC = Ocean

CT = Conductivity (Salinity) & Temperature

DL = Delrin Housing

1 = RS-232 Data Output

000 = No Pressure Transducer

0 = Standard RTD Thermometer

For more Information

Please contact D-2 Incorporated for additional specification information or quotation information. We hope to hear from you soon!



D-2, Inc.

6 Otis Park Drive, Bourne Ma, 02532

P 508-329-2046

E dfougere@d-2inc.com

D-2.com

Specifications subject to change without notice.
05/2026 ©2026 D2 Inc. Other products and company names mentioned herein may be trademarks and/or registered trademarks.