



Smart Sensors
for a Dynamic Sea

**AUV-CTD GLIDER
CONDUCTIVITY
(SALINITY)
TEMPERATURE
DEPTH SENSOR**

D2 CTDs vs the Competition

Performance Factor	Inductive	Pumped	D2
Accuracy	+/-0.003 S/M	✓ +/-0.0003 S/M	✓ +/-0.003 S/M
Durability	Implosion Issues	Pump Failures	✓ No Pump Failures or Implosions
Power Draw	✓ 40 mW	225 mW	✓ 40 mW
External Field	Yes	✓ No	✓ No
Biofouling Solution	None	TBT and Small Diameter	✓ EPA Approved Biofouling
Production Lead Time	✓ Fast	Very Slow	✓ Fast
Calibration Lead Time	✓ 3 Weeks	Extremely Long	✓ 2 Weeks
Pump	None	Required	✓ Add-On Available for Biofouling
Silent	✓ Yes	No	✓ Yes

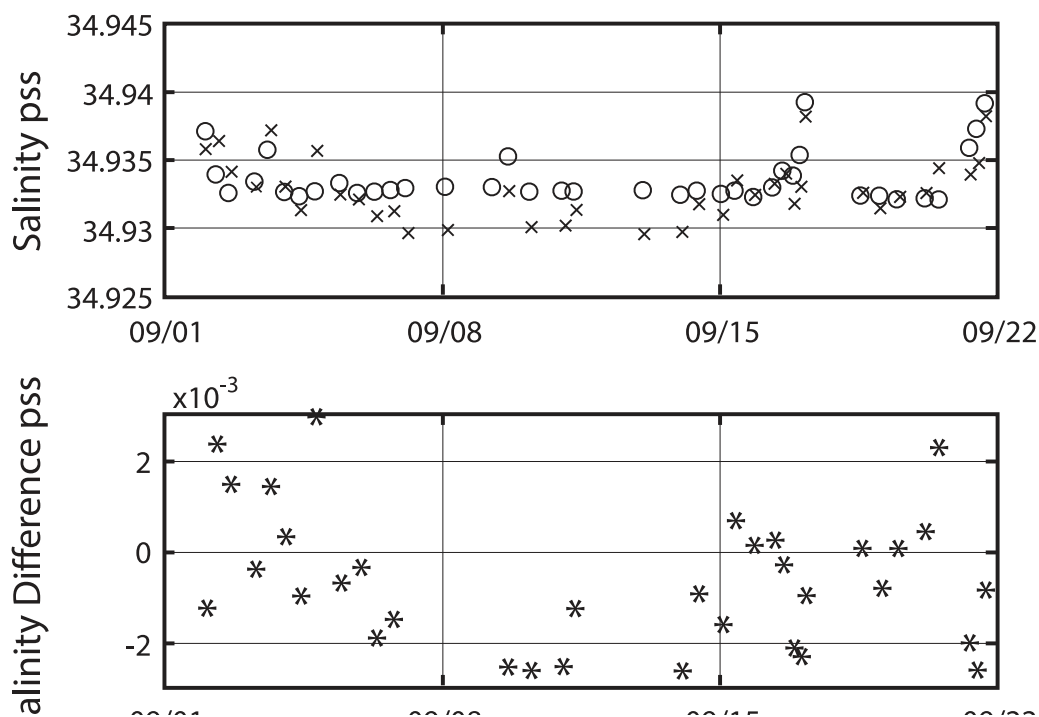

Comparison of salinity estimates on the -0.49°C potential temperature surface found around 2000-m depth in the BGOS cruise region. (Top) Hybrid CTD salinity estimates on each cast are indicated with the x values, while the o values are for the ship CTD data. (Bottom) The salinity difference estimates (Hybrid CTD minus ship CTD).

For more Information

Please contact D-2 Incorporated for additional specification information or quotation information. We hope to hear from you soon!



D-2, Inc.
 6 Otis Park Drive, Bourne Ma, 02532
 P 508-329-2046
 E dfougere@d-2inc.com
 D-2.com

Specifications subject to change without notice.
 05/2026 ©2026 D2 Inc. Other products and company names mentioned herein may be trademarks and/or registered trademarks.

AUV-CTD Dimensions

AUV-CTD with Protective Frame Removed

Delrin curved top plate customizable to match vehicle outside diameter

Full length high-speed temperature thermistor

RS-232 real time data output

High accuracy pressure transducer specific to user depth

D-2 Hybrid CTD free flushing closed field conductivity (salinity) cell

Standard hydraulic MS port for calibration



Top plate can have any radius to match AUV diameter

RS-232 real time data output via 5 pin connector



D2 AUV-CTD SENSOR



AUV-CTD Delrin Housing



Designed for UUV's, AUV's, Gliders, Floats, Profilers, etc. The AUV-CTD can fit into existing platforms seamlessly providing Conductivity, Temperature and Depth (Pressure) real time data, Salinity and Sound Velocity Outputs.

Features of the AUV-CTD Sensor

- Novel New Hybrid 100% Internal Field Free Flushing Conductivity Sensor
- High Speed Sheathed RTD ~ TC = 60 mS (2 mm Diameter) with Integral Temperature Reference Standard
- Industry Standard Silicon Pressure Sensor Full Thermally Compensated
- High Speed Sampling, Programmable
CTD: 2-32 Hz sample rate
ULP-CTD: 1-2 Hz sample rate
- Runs On Low Power:
CTD: 20 mA at 7 to 13 (140 mW)VDC
ULP-CTD: 4 mA at 10 VDC (40 mW) (Range 7 to 13 VDC)
- Free Flow Conductivity Sensor, Aspirates well even down to 5 cm/s vehicle speeds.
- OEM housing available, this AUV-CTD can be adapted to fit into any platform.
- Conductivity range of 0-7 S/m
Temperature -2 – 35C
Delrin Housing. Max Depth 2757 Meters.
OEM Custom Versions Available.
- Fast Delivery Times
- Quick Calibration Turnarounds
- Full Length Temperature Probe, Based on Simple to Calibrate Platinum Resistance Thermometer, no need for high-cost multiple point temperature calibrations.

Options

- Pressure Transducer Depth Range
- Frame
- User Set Depth Options
- Ultra Low Power
- Top Plate Can be altered to Match Outer Diameter of your vehicle.
- System Can Be Pumped if Desired

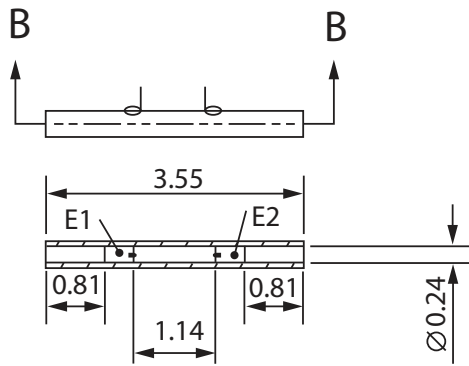

Conductivity Cell Cross Section Diagram

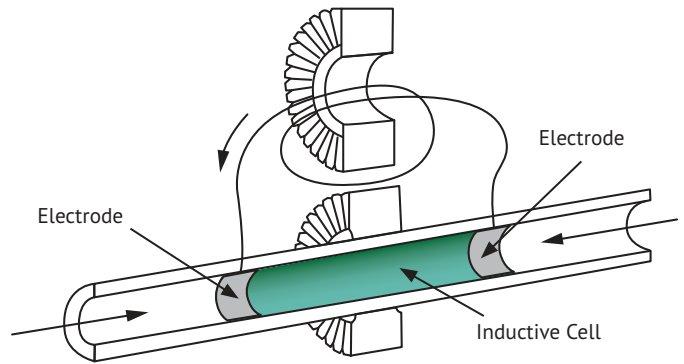

Conductivity Cell Electrical Diagram

The D2 CTD utilizes a new Hybrid Conductivity Sensor; a completely new concept in oceanographic conductivity/salinity measurement. It has the same performance advantage of a 3-electrode sensor where the end electrodes are electrically tied together ensuring there is no external electric field. Electrodes coupled with a novel inductive drive, eliminates the need for additional center electrode, or other electrodes in the measurement field. The two-electrode sensor with inductive drive is hence called a Hybrid as it incorporates the best aspects of both the electrode type & inductive type conductivity sensors that both have a history of performance oceanographic conductivity measurements.

The inductive drive creates an electric current that flows through the center measurement region, the current flows in direct proportion the conductivity of sea water. This current is collected by the end electrodes and passed through a simple current to voltage transformer.

The rate as which current flows in the sensor is then direct proportion to the conductivity of sea water and the magnitude to the drive signal. The drive signal level can be precisely controlled, and the collection electrodes and shorting path can be constructed to have very low impedance as compared to the external sea water path, hence the 'all' of the current flows through the shorted electrode path, and hence the current measurement transformer. The result is a two-electrode cell that is less than ½ the length of a traditional a 3-electrode cell and has a large center diameter. A sensor that can free pass water through the cell without the need for a pump in almost all applications. In applications where a pump is needed, say for biological control, this can be easily added as the sensor measurement volume is 100% enclosed in the sensor and the addition of tubing a pump will not affect the calibration. The sensor is fully described in US Patent #9,410,910.

Typical Performance	Range	Resolution	Initial ACCURACY	Typical Stability
Conductivity	0 – 7 S/M	.00001 S/M	+/- 0.0003 S/M	+/- 0.0003 S/M/Month
Temperature	-5 – 35 °C	.0001 °C	+/- 0.001 °C	+/- 0.002 °C/Month
Pressure / Depth	0-11,500 dbar	.001% F.S.	+/- 0.015% F.S.	+/- 0.02% F.S. Year

D-2 CTD Lab and Field Data

The top graph to the right is from the Bermuda Institute for Ocean Sciences BIOS showing the D2 CTD against the industry standard CTD from the Ocean Surface to the Ocean floor. This data shows that “D-2 Inc. CTD obtains data comparable to the operational sensors now being fielded by the ocean observing community”.

The lower graph is data collected by the Woods Hole Oceanographic Institution at their Clark Lab stratified salt response tank. Descent speeds of 10 cm/s = black, 20 cm/s = blue, 30 cm/s = red. The response tank data shows that the D-2 CTD has uniform response regardless of lowering rate. This generates simplified data processing of salinity values & salinity spiking elimination.

D-2 CTD Data Output

Real-time CTD data is transmitted via the RS-232 in ASCII characters. The D2 CTD must be externally powered, data can be logged in internal SRAM memory or it can be telemetered directly to the host vehicle in ASCII ‘Calibrated’ Units in real time. Data string can include Salinity & Sound Velocity in units of users choice.

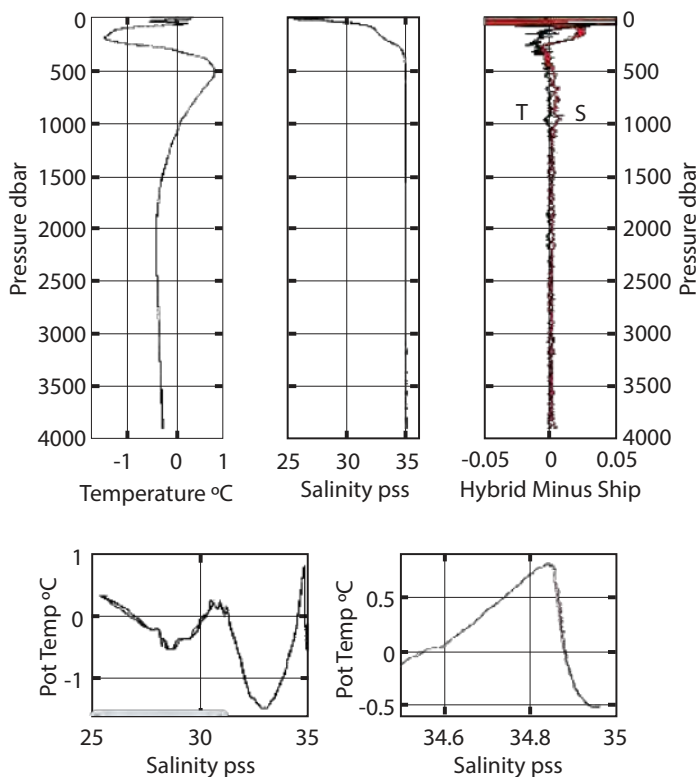

Comparison of salinity estimates on the -0.49°C potential temperature surface found around 2000-m depth in the BGOS cruise region. (Top) Hybrid CTD salinity estimates on each cast are indicated with the x values, while the o values are for the ship CTD data. (Bottom) The salinity difference estimates (Hybrid CTD minus ship CTD).

The CTD supports numerous auxiliary sensors via eight A/D channels and the one RS-232 data channel which allows connecting Oxygen, Ph, Turbidity and other popular sensor packages.

The ASCII Data Output is the same configuration as other industry standard sensors, making our sensor interchangeable with existing fielded sensors of other manufacturers.

D-2 Calibration

The CTD can be deployed for up to 3 years, however when it does require recalibration, D-2 Inc. has an ISO Cal Lab and will recalibrate all our CTD sensors in 2 weeks or less.

D-2 Depth Sensor

The D2 CTD uses a high-accuracy, high-resolution pressure sensor. The D2 CTD’s strain-gauge pressure sensor is offered in a wide range of full-scale values up to 11,500 decibars. Pressure outputs are fully compensated for the effects temperature and is performed internally using state of the art numerical techniques.

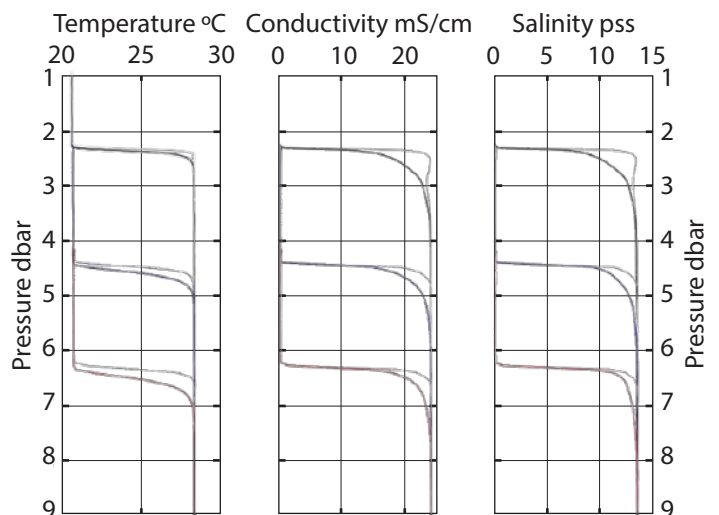

Profiles of (left) temperature, (middle) conductivity, and (right) derived salinity vs pressure from lowerings of a Hybrid CTD sensor in the WHOI Dynamic Response Test Tank facility. Shown are lowerings at speeds of 0.10 (black curves), 0.30 (blue), and 0.50 (red) m s⁻¹. Profiles at the different lowering speeds have been offset vertically by 2 dbar for clarity. Salinity was derived with no corrections for the dynamic response of the sensors. Shown in gray are the profiles with corrections applied based on sight-pole filter models of the sensor responses for T and C with salinity derived from these corrected data.