



ANELLO X3

World's Smallest and Lightest 3-Axis Optical Gyroscope IMU

The ANELLO X3 is a small, compact and highly reliable, 3-Axis Optical Gyroscope Inertial Measurement Unit (IMU) for today's autonomous applications in GPS denied environments.



ANELLO X3

The ANELLO X3 leverages three state-of-the-art ANELLO SiPhOG™ (Silicon Photonics Optical Gyroscope) units as low-noise and low-drift optical smart sensors each containing its own independent 6-Axis redundant IMU sensor.

ANELLO replaces traditional discrete optical components with its patented photonic integrated circuit (PIC) technologies, making the ANELLO X3 the smallest and lightest commercially available 3-Axis optical gyroscope in the world. Optical gyroscope measurements are trusted for their low-drift performance under harsh environments including shock, vibration, and thermal gradients.

Requiring only an unregulated power input, the ANELLO X3 outputs data via a flexible, high-speed serial channel.

The all-digital ANELLO X3 provides high-bandwidth, low-drift angular rate measurements on all axes. The integrated triple-redundant 6-Axis MEMS IMUs provide fully calibrated acceleration measurements and auxiliary rate sensor data for maximum fault detection coverage. A hardware built in test (BIT) output line signals fault detection, alongside diagnostic messages and the BIT data word. The internal circuitry uses three ASIL-B ready functionally safe microcontrollers, as well as an ASIL-D rated master CPU.

A Sync/PPS input line allows the SiPhOG and IMU measurements to be time aligned with an external clock such as a GNSS/GPS pulse per second (PPS) line.

FEATURES

3-Axis SiPhOG™	< 0.03 m/s/√hr Accel VRW
21 Total Sensor Channels	< 0.5°/hr Gyro Bias Instability
Safety Rated RTOS and CPU	< 0.05°/√hr Angular Random Walk
RS-422 or UART	Easy to Time Synchronize
< 20μG Accel Bias Instability	Fully Calibrated Measurements
Patented Photonic Integrated Circuit Technology	Triple Redundant, 6-Axis MEMS IMUs, each with independent CPU/Power Subsystems (18 Axes)
ASIL-D Ready	

FUNCTIONAL BLOCK DIAGRAM

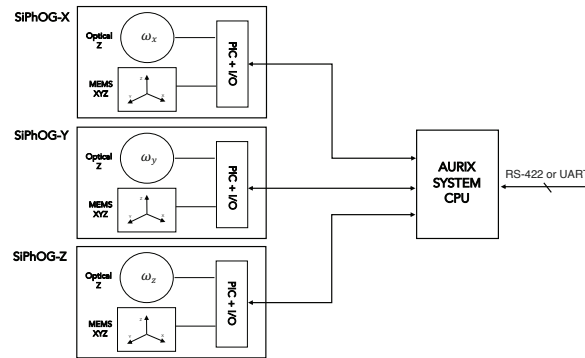

TECHNICAL SPECIFICATIONS (COMMERCIAL)

XYZ Optical Gyroscope Performance

Rate Range	+/- 200°/s
Bias Instability	< 0.5°/hr
Angle Random Walk	< 0.05°/√hr
Scale Factor Error	< 0.1% (0 - 200°/s)
Scale Factor Over Temp	< 0.5%
Bandwidth	> 100Hz (Configurable)
Vibration and Acoustic Sensitivity	Not Measurable

Redundant 6-Axis IMU Performance

Number of Redundant MEMS IMU	3	
Range	16g	up to 400°/s
Bias Instability	20μg	1.5°/hr
Random Walk	0.03 m/s/√hr	0.3°/√hr

Serial Communication

UART or RS-422	Up to 921600 Baud
UART or RS-422 Sample Rate	Up to 200Hz

Electrical

Connector	SAMTEC 14-pin Male
Sync / PPS In	TTL
Built-In-Test	TTL
Voltage Supply	4-24 VDC (regulated)
Power Consumption	< 5.0W

Environmental

Sealing	IP54
Temperature ¹	-10 to +50°C
Shock	20g, 20ms, 6 Shocks per Axis
Vibration	4gRMS, 20-2KHz, 30min per Axis

Physical

Size	2" (51mm) x 2" (51mm) x 1.75" (44.5mm)
Weight	< 0.4 lbs (182g)

Lifetime

MTBF	> 50,000 hours
------	----------------