

HFDI-150

HEAVY FUEL ENGINE

Twin-Boxer Ultra-Smooth

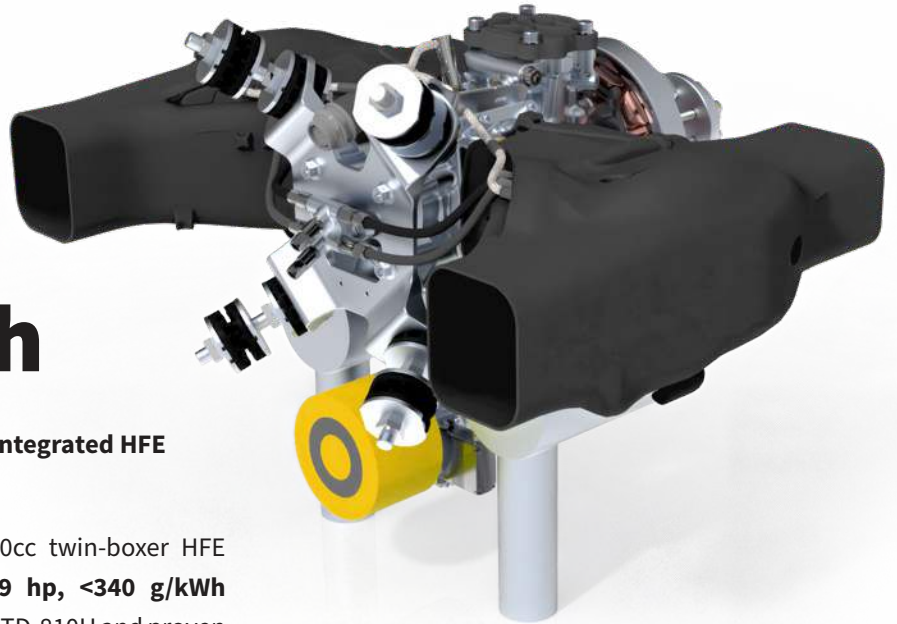

Opposed two cylinder 2-stroke FlexDI™ Fully Integrated HFE Propulsion System for UAVs

Built on the proven 75cc architecture, the 150cc twin-boxer HFE delivers ultra-smooth heavy-fuel power - **11.9 hp, <340 g/kWh efficiency in a 10.4 kg system**. Qualified to MIL-STD-810H and proven through 25,000 operational hours in the field.



Plug-and-fly integration, faster to flight

Compact form, direct coupling and integrated Engine Management System mean faster install, cleaner wiring and lower integration risk.



Endurance efficiency

FlexDI™ heavy-fuel combustion at <330 g/kWh extends range and offers superior fuel consumption.



Ultra-smooth power

Twin-boxer layout delivers >11.9 hp with low vibration for cleaner data and reduced airframe fatigue.



Mission-grade durability

MIL-STD-810H qualified; FAR 33.49(b) 3×150 h back-to-back plus 500 h mission-profile testing - confidence from dyno to field.

FlexDI™ Fuel Injection

8-micron precision, mission-level efficiency

Orbital's FlexDI™ atomises fuel to ~8 µm droplets (vs ~120 µm conventional), delivering a cleaner, more complete burn. The result is >30% lower cruise fuel use, high specific power (>70 kW/L), and assured starts in -30 °C conditions with automatic altitude compensation to high Density Altitudes.

FlexDI™ runs JP-5/JP-8/Jet A/Jet A-1 or gasoline, meets MIL-STD-1474D noise targets, and uses electronic oil metering for consistent lubrication.

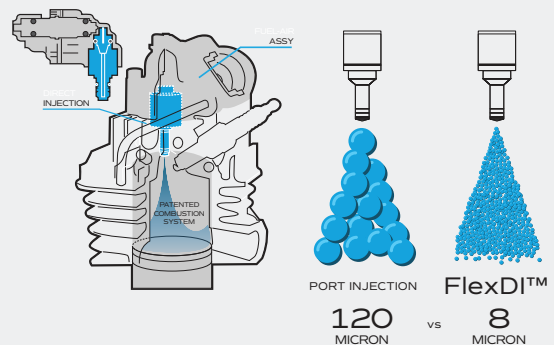

FlexDI™ turns advanced combustion control into tangible mission advantage.

contact@orbitalcorp.com.au | www.orbitaluav.com

[in](https://www.linkedin.com/company/orbitaluav) orbitaluav [✉](https://twitter.com/OrbitalCorpASX) @OrbitalCorpASX

ENGINEERED TO WIN



HFDI-150

Twin-Cylinder FlexDI™ Fully Integrated HFE Propulsion System for UAVs



SOLAR



COLD



DUST



RAIN

ENGINE SPECIFICATIONS

Engine Configuration	150cc, Air-cooled, opposed two cylinder 2-stroke with Orbital Flex DI
Power	11.9hp (8.8Kw) @ 6,500rpm
Fuel Consumption (BSFC)	~330 g/kWh @ typical cruise
Fuel Compatibility	JP5, JP8, Jet A, Jet A1 (able to operate on gasoline)
Weight	~10.4kg Integrated Propulsion System (includes ECU, mount, pumps, harness, propeller)
Engine Management	Orbital FlexECU with CAN Communication
TBO	500 Hours

INTEGRATED PROPULSION SYSTEM

Thermal Management	Light weight aerodynamic cowls
Exhaust System	Light weight acoustic/power optimised
Vibration Isolation	Dynafocal tuned mounting system
Electrical Power	Configurable Engine Management System alternator (with remote-start capability)
Fuel and Oil System	Integrated pumps and lines with consumption monitoring
Propeller	Orbital OptiProp propeller simulation and selection

OPERATING ENVIRONMENT

Max. Operating Altitude	20,000' AMSL
Operating Temperature	-30 to 55 °C including start
IP Rating	MIL Spec. Sand, Dust, Rain, Salt Fog
Environmental Conditions	MILSTD810H

Orbital helps UAV manufacturers outperform their competition by delivering integrated propulsion systems engineered specifically for maximum reliability, seamless integration, **and mission-critical performance.**



Image shows Aerosonde MK 4.8 Fixed Wing/VTOL, courtesy and copyright of Textron Systems.

1.2 Million hours of in-field service with multiple Tier 1 Defence customers - Orbital propulsion systems deliver the integrated reliability and performance to make your UAV a market leader.

ENGINEERED TO WIN  **ORBITAL®**