

## 23-06 2200Kv Module

### 1 Features

---

#### Performance & Control

- Velocity control with tunable PIDs & 2nd order feed forward
- Field Estimated Control: Best-in-class efficiency (up to 20% efficiency boost in hover)
- Propeller positioning capabilities
- 3D reversible, no delay while crossing zero
- Industry-leading rise & response times
- Regenerative & active braking
- Active freewheeling
- Fast FET switching, use of gate drivers
- Voltage controller
- PWM controller
- Coast and brake modes
- No minimum speed
- Backdrivable

#### System Integration

- Motor with built-in ESC & position sensor
- Communication protocols: DShot (150-1200), 1-2ms PWM, Serial (UART) w/ access to control parameters, Oneshot (42,125), and Multishot

#### Safety & Reliability

- Over-current, over-voltage, & over-temperature protection
- Access to standard & custom telemetry
- Motor health monitoring
- Safe arming procedure

### 2 Applications

---

- Drone Propulsion
- Robotics



### 3 Description

---

The 23-06 2200Kv Module is an ultra-compact, light-weight drone propulsion module that tightly integrates a high-performance 23-06 motor with a 30A, 6S ESC and position sensor. It has an open and closed loop controller designed primarily to drive propeller loads. Its performance is comparable to or better than other 23-06 sized motors and can operate at any speed between -32,000 and 32,000 RPM thanks to its sensed control.

The motor can be driven with an integrated PID velocity controller with a second order polynomial feed forward, which is ideal for propeller applications. This sits on top of a voltage controller, which compensates for varying input voltages such as battery charge levels. Finally, the core is a raw PWM controller. Any of the above controllers can be used by the user.

## 4 Motor Specifications

Description	Symbol	Value	Unit	Notes
Speed Constant	$K_v$	2200	RPM/V	
Torque/EMF Constant	$K_t$	0.0043	N m A <sup>-1</sup>	
Resistance	$R$	0.038	$\Omega$	motor, 25°C
Effective Resistance	$R_e$	0.045	$\Omega$	motor + controller, 25°C
Mass	$m$	37.4	g	Without wires/accessories
Continuous Torque	$\tau_c$	65	N mm	25°C ambient
Continuous Torque	$\tau_b$	130	N mm	In airflow, 25°C ambient
Continuous Current	$I_S$	15	A	Motor current, 25°C ambient
Continuous Current	$I_{SR}$	30	A	Motor current, in airflow, 25°C ambient
Pulsed Current	$I_{SP}$	65	A	Motor current, 100ms, 25°C ambient
No Load Speed	$\omega_0$	2166	rad s <sup>-1</sup>	@ $V_{CC} = 10\text{ V}$
No Load Current	$I_0$	1.3	A	@ $V_{CC} = 10\text{ V}$

## 5 Electrical Specifications

Table 1: Absolute Maximum Ratings

Description	Symbol	Min	Max	Unit	Notes
Supply Voltage	$V_{CC}$	-0.3	30	V	
Digital Logic Voltage	$V_L$	-0.3	7.3	V	3.3 V system, 5 V tolerant
MCU Temperature	$T_{MCU}$	-20	105	°C	Controller will self-limit performance when approaching max temperature

Table 2: Recommended Operating Conditions

Description	Symbol	Min	Max	Unit	Notes
Battery Cells	$S$	2	6	$S$	Standard Li-on/po. Use w/ caution on 6S.
Power Supply Voltage	$V_{CC}$	5.4	24	V	Ensure motor regen does not exceed voltage limit. Use built in regen limiter or use an external load.
Ambient Temperature	$T_a$	-10	50	°C	Higher possible with reduced performance

## 6 Electrical Interface

---

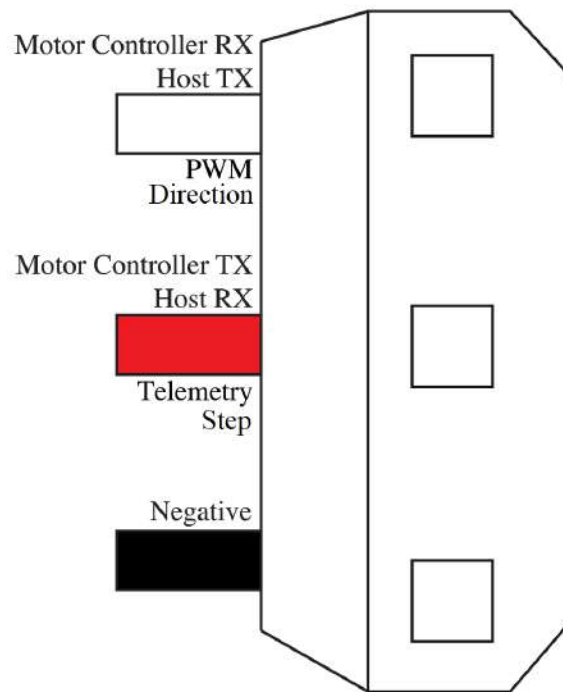

Figure 1: JR Servo Communication Connector

### 6.1 Communication Wiring

The standard communication connector is a JR type servo connector with 15cm of wire. These connectors have 0.1in spacing and can be inserted into standard perfboard and breadboards with a 3x1 0.1in male-to-male header. Black is minus (ground). Red is motor controller TX (host RX) and telemetry output. White is motor controller RX (host TX) and pwm input.

### 6.2 Supply Wiring

Power is transmitted to the 23-06 2200Kv Module via the two supplied 16 AWG (1.31 mm<sup>2</sup>), silicone encased, 15cm long wires. Black is minus (ground). Red is positive.

## 7 Mechanical Interface

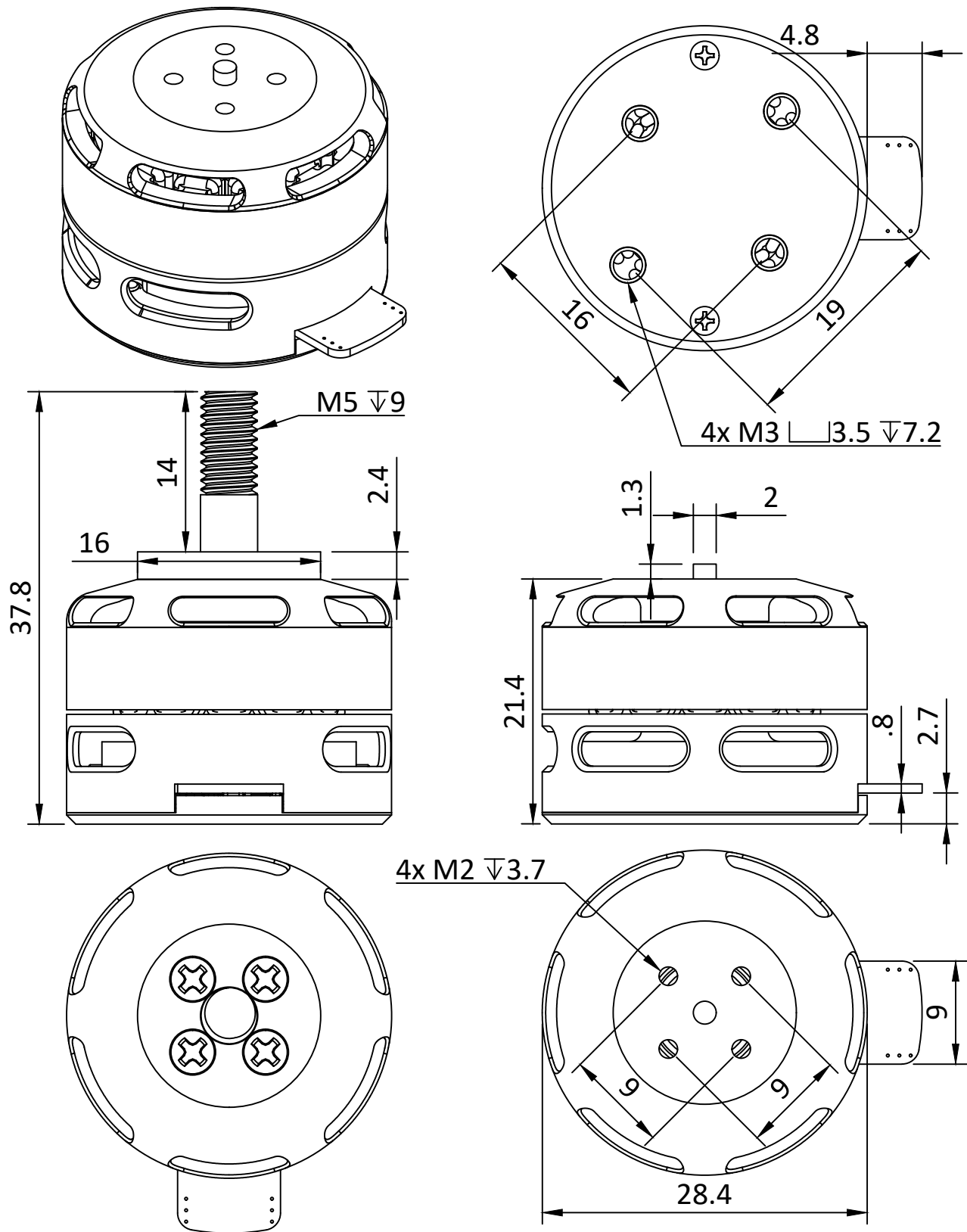

## 8 Safety Features

---

### 8.1 Over Current Protection

The ESC uses a predictive method for over current protection. The motor controller will not apply a voltage which would put the controller or motor at risk of over current. This is in contrast to a reactive current controller, which only performs limiting once large currents have been detected, and thus already put the hardware at risk.

### 8.2 Over Temperature Protection

The controller has an onboard temperature sensing circuit. If the temperature sensor detects a temperature that is approaching the controller's maximum temperature limit the controller will begin to derate, resulting in lower speeds and torques than expected. The controller will continue outputting as much power as possible without exceeding its thermal limit. If the temperature drops the controller will automatically exit derate mode and continue normal operation.

Though there is no temperature sensor in the motor's coils, the controller contains a predictive model which estimates the coil temperature. The same derating process as above is applied to the estimated coil temperatures, applying as much power as possible without causing damage. This protection ensures that large loads or stalled conditions do not overheat and damage the motor coils and magnets.

### 8.3 Over Speed Protection

A soft limiter will reduce the voltage applied to the motor once  $\omega_{max}$  is exceeded. The farther the speed is above  $\omega_{max}$  the lower the output voltage of the controller. In extreme overspeed situations the motor acts as a brake, effectively shorting the three phases of the motor together. This will protect the motor from extremely large load changes, poor PID tuning values, and the unlikely chance of a runaway condition. This feature will fight an externally applied load that causes an over speed, but is not able to guarantee the prevention of an over speed condition in this situation.

### 8.4 Regeneration Voltage Protection

The 23-06 2200Kv Module is a four quadrant motor-controller, which means it can both motor and generate in both directions. One problem when the motor is generating is the voltage can spike if the connected electronics cannot absorb the energy that is being generated. Power supplies cannot generally absorb energy, while rechargeable batteries and capacitors can. This leads to a voltage spike that may destroy the motor and any attached equipment.

The controller prevents these spikes from occurring by limiting the voltage applied to the motor. If an out of allowable range generation occurs, the motor will decrease its own generation, thereby protecting the circuitry. This protection does not prevent the damage from externally applied voltages.

### 8.5 Command Timeout Protection

A user settable timeout automatically puts the motor in to coast mode if it does not receive a message valid message within a specified amount of time. The normal operation resumes upon receiving a new message.

### 8.6 Input Connection Protection

All exposed pins are protected with ESD diodes and a small amount of reverse polarity protection. Do not knowingly or intentionally apply reverse polarity or out of limit voltages to the exposed pins.

## 8.7 Watchdog Protection

In case of an unlikely error in the controller that causes it to freeze, the controller will automatically reboot. While this may allow for a recovery, all normal startup procedures are re-performed and any arming sequence or auxiliary commands must be redone.

## 9 Motor Performance

### Meaning of colored area(s) on graphs:

**Yellow** area: Motor over-speed. Note: the motor can physically reach these speeds, but Vertiq's controller will limit the motor's speed to the bottom of this region by default. Operation in the yellow area may result in mechanical failure.

**Red** area: Torque range above "still-air continuous." Note: users should be careful operating in the red area as the motor requires air cooling in this range and the amount of air flow depends heavily on the propeller.

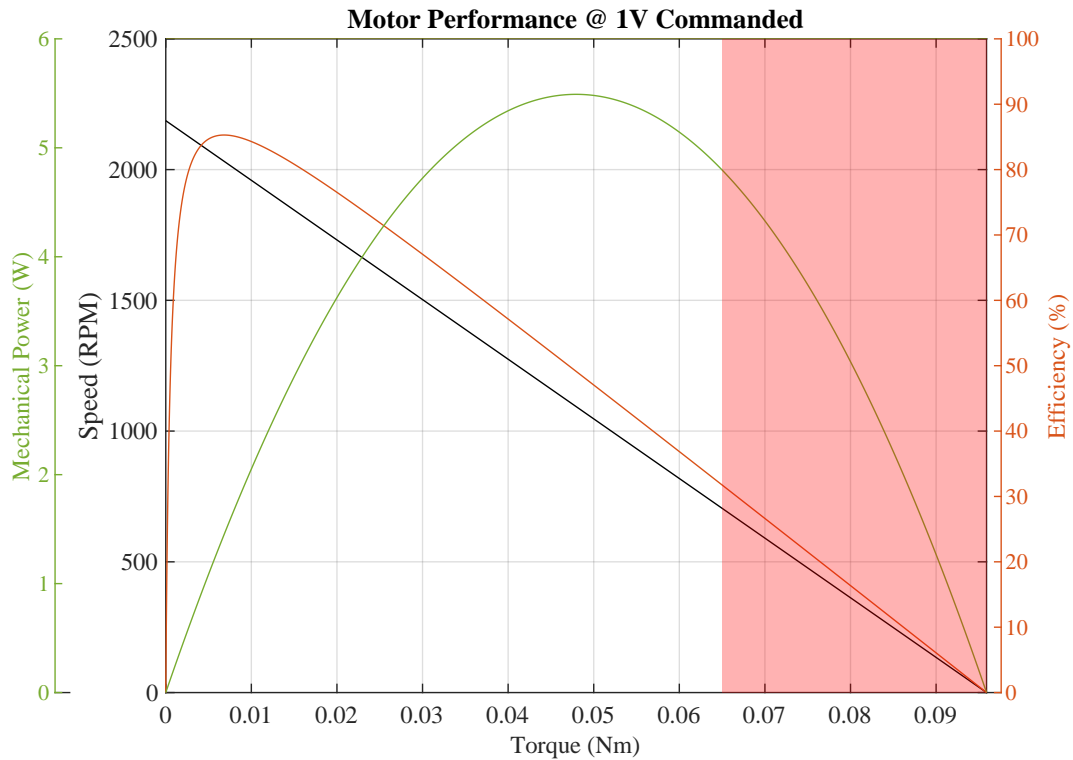

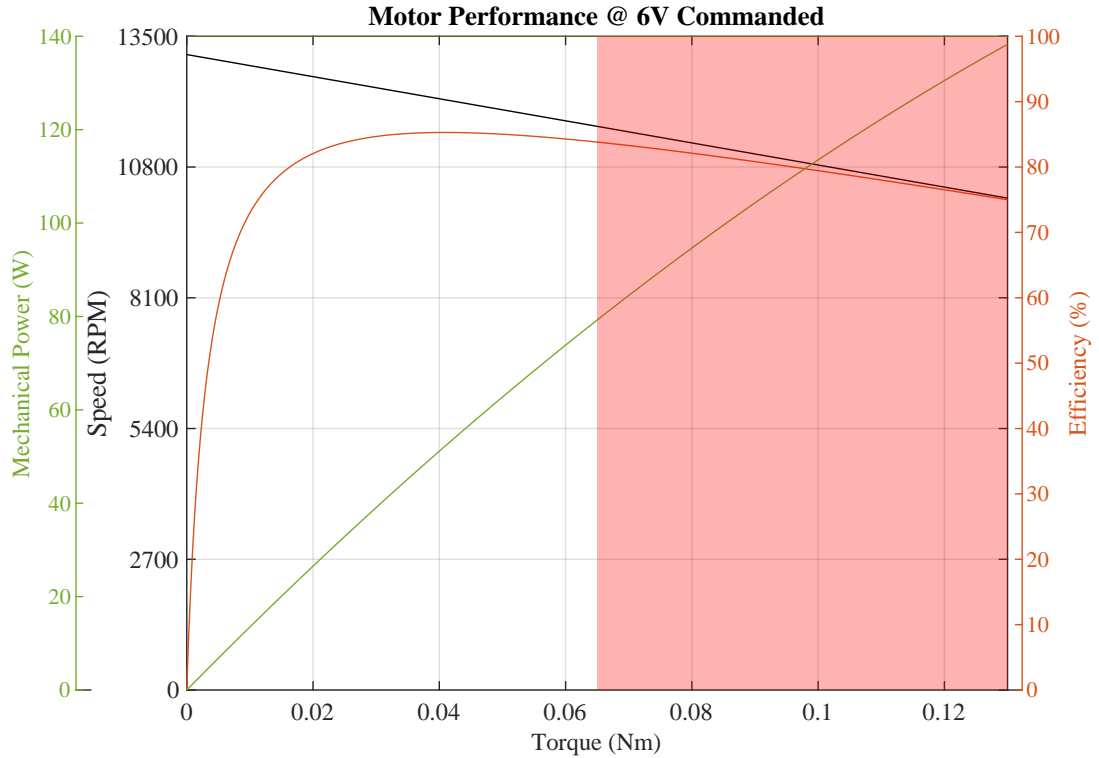
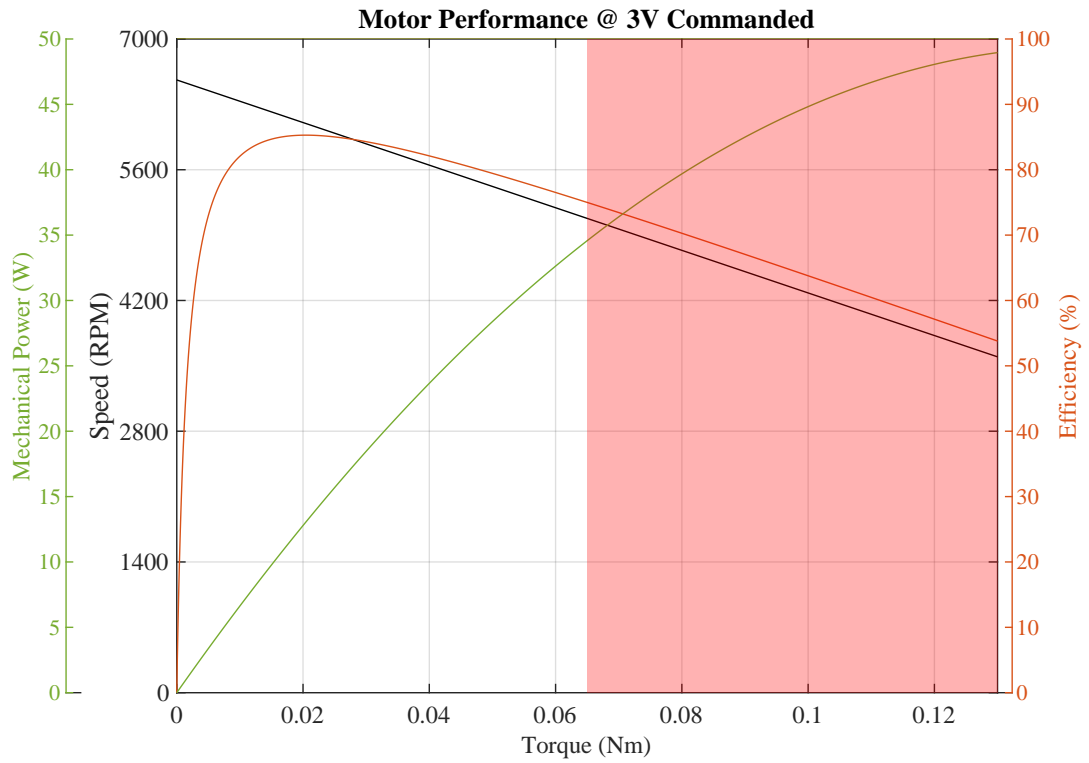



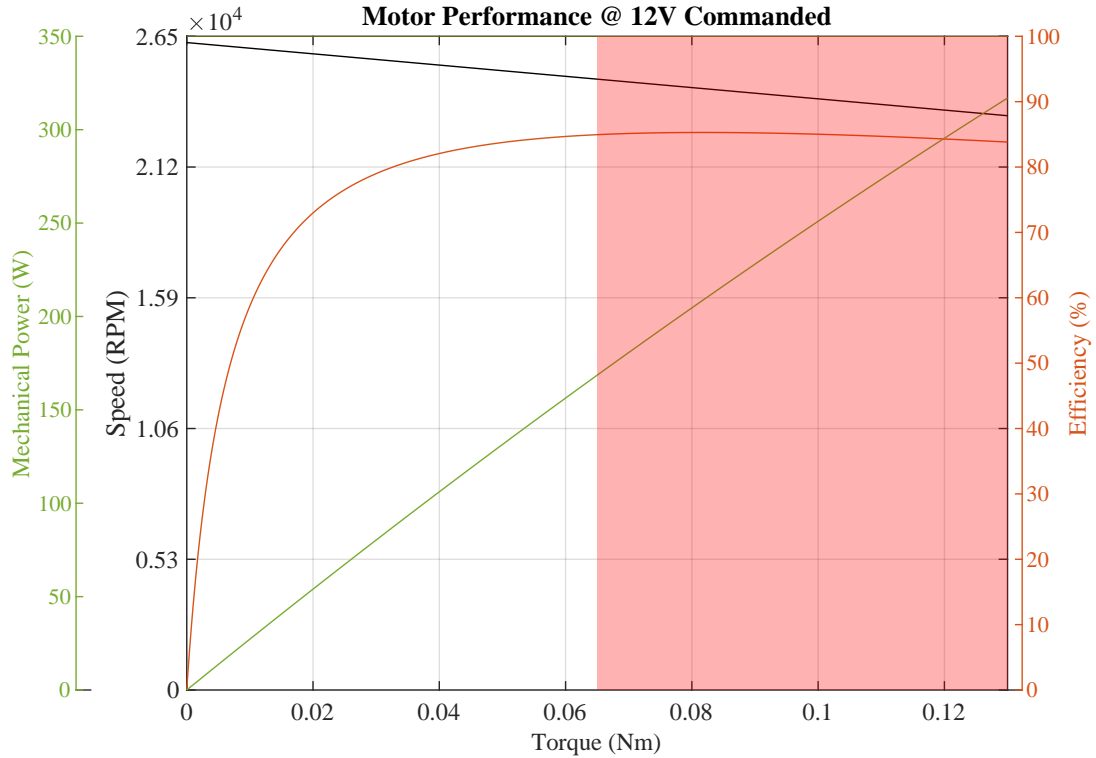
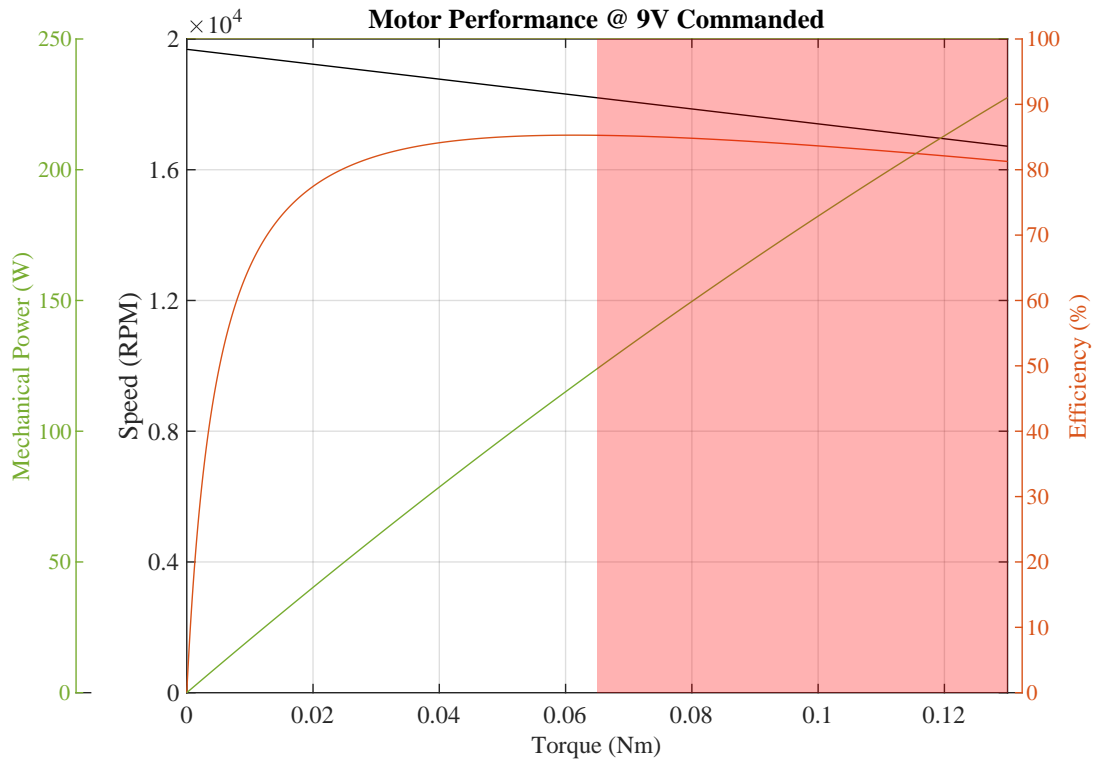

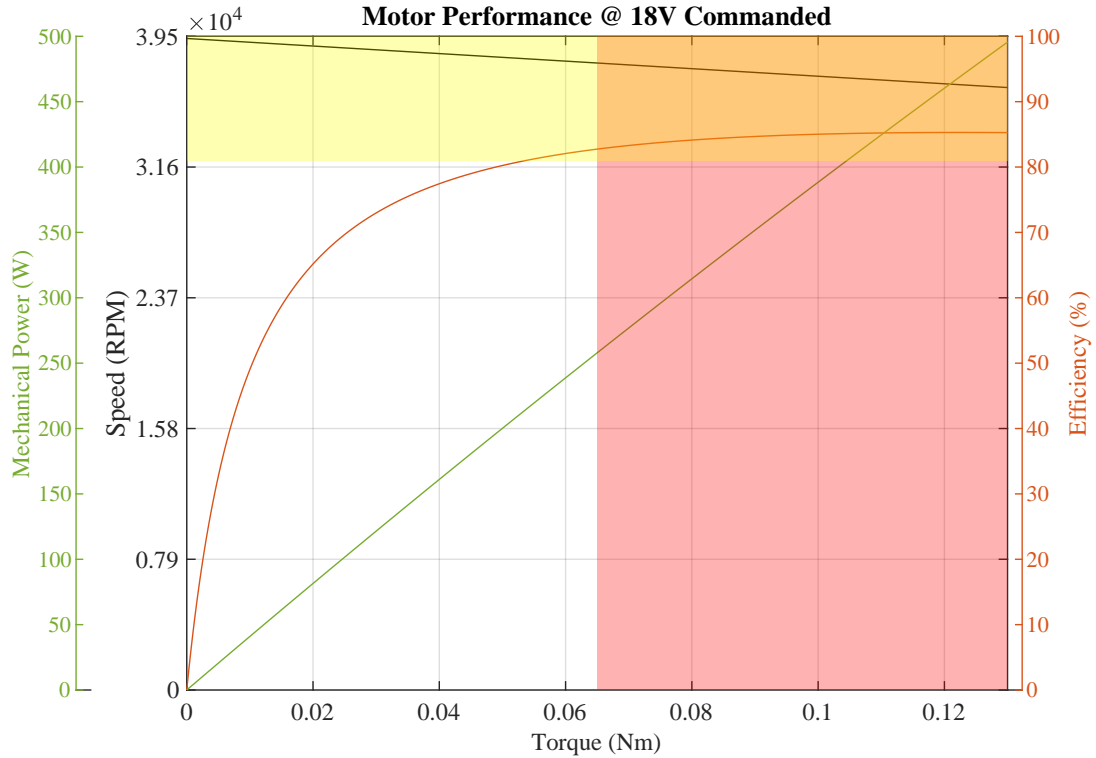
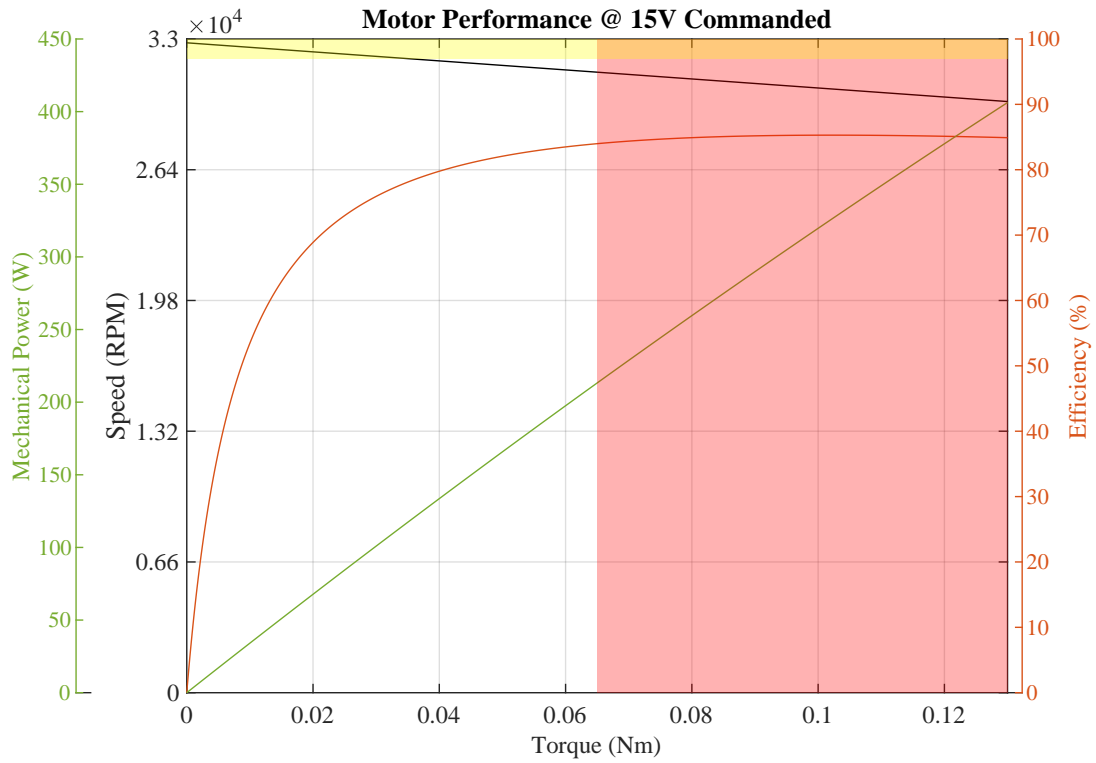

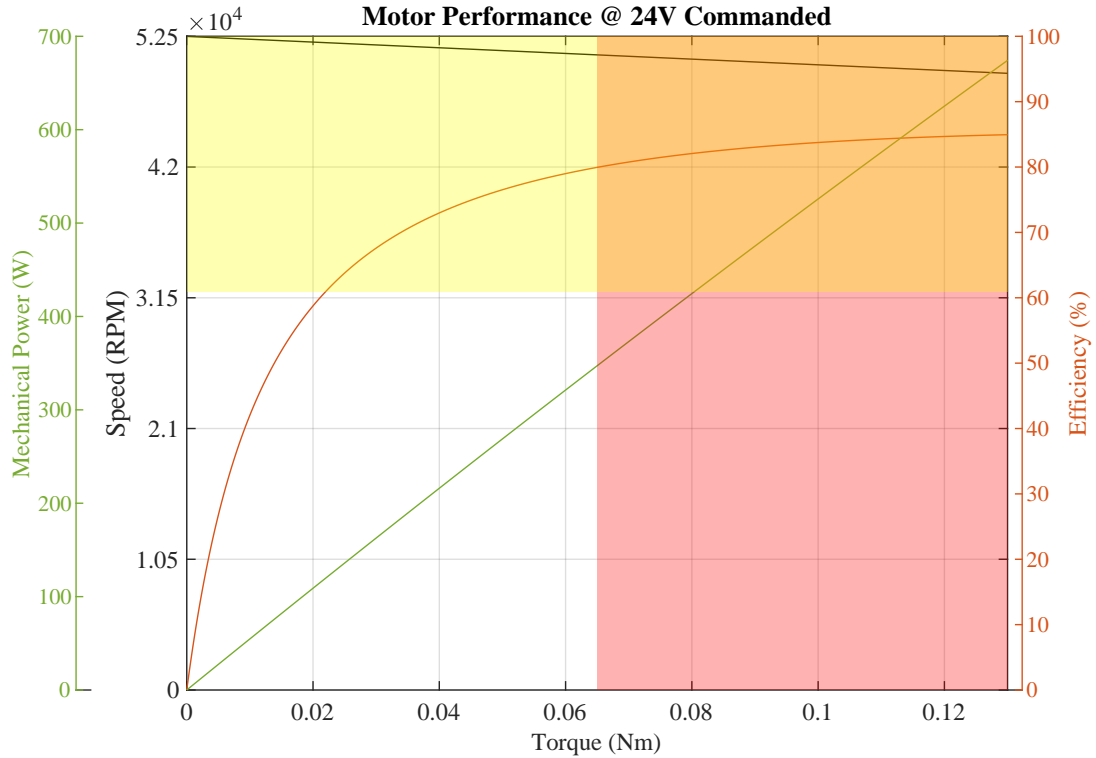
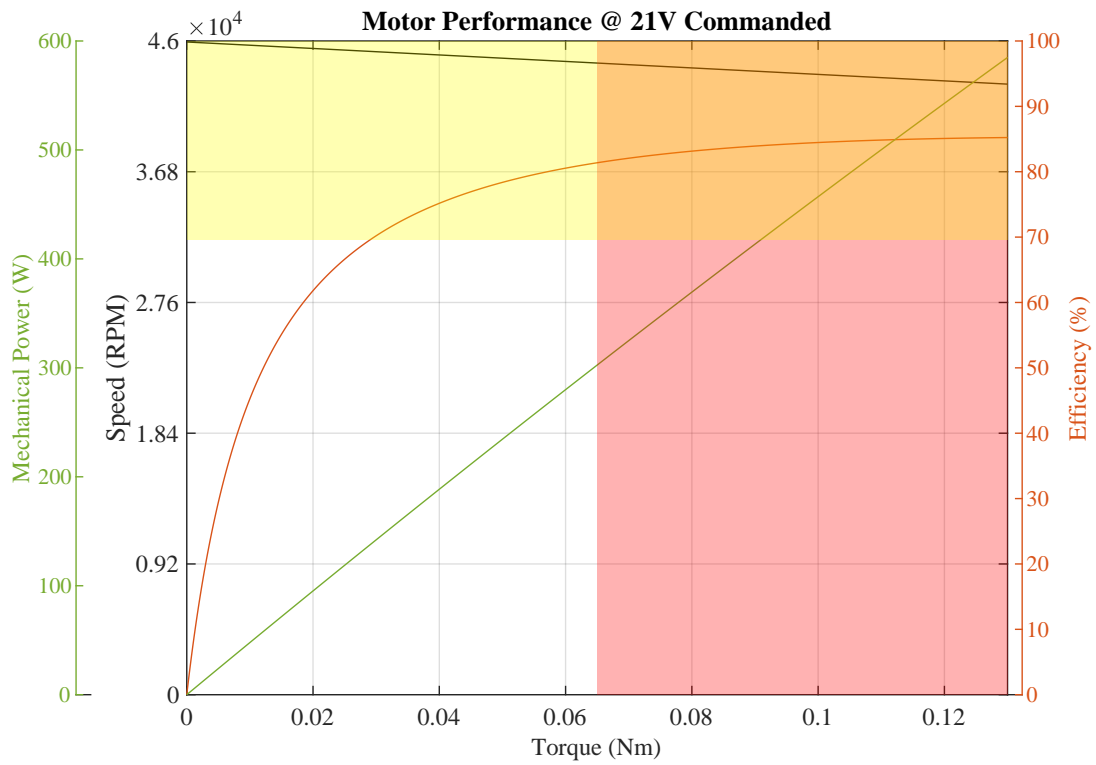

## 10 Revision History

---

Table 3: Revision History

Version	Date	Changes
1.0	2019-03-05	Initial Version
1.1	2019-07-25	Update figures
1.2	2022-08-24	Update features, description, and images