

DA 30 Technical Specification

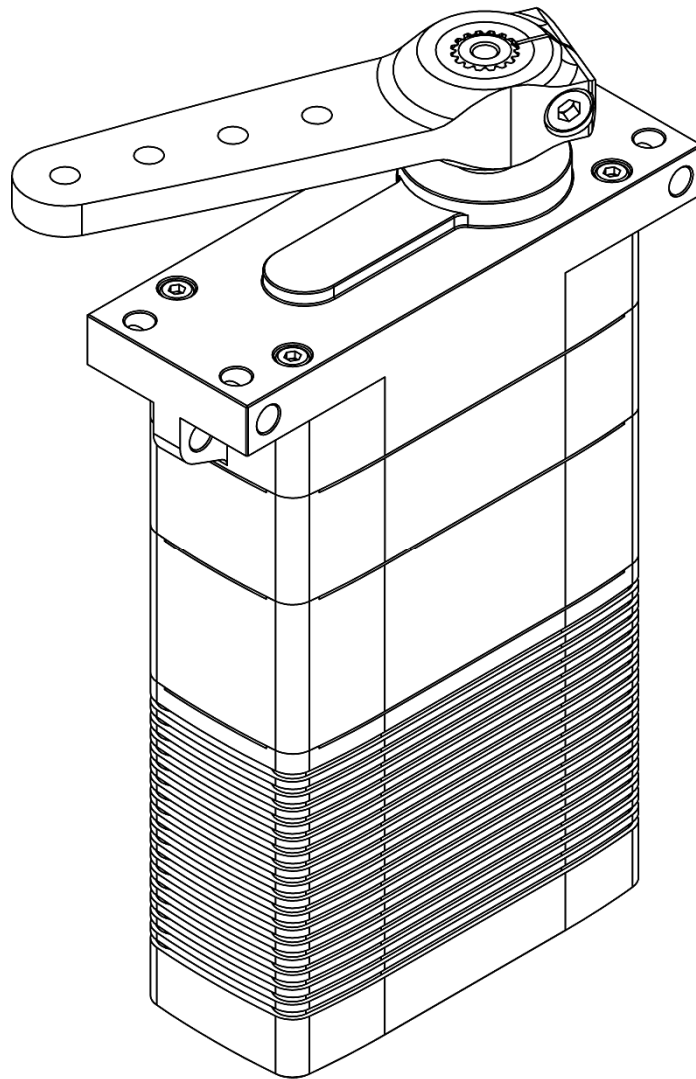

DA 30-30-5224



Content

1. General Description	3
2. Operating Data	4
3. Performance	5
4. Command Signal	6
4.1. PWM Command Interface	6
4.2. RS 485 Command Signal	6
4.3. RS 485 Protocol Specifications	7
4.4. Position Feedback Signal (PWM Versions)	8
4.5. Position Feedback Value (RS 485 Versions).....	9
5. Materials and Protective Features	10
6. Dimensions	10
6.1. Installation Dimensions	11
6.2. Output Shaft Spline	12
7. Electrical Connection Options	13
8. Accessories	19
8.1. Aluminum Servo Arm	20
9. Item Number System.....	21

1. General Description

To guarantee maximum safety and reliability, our DA 30 features a brushless motor and a contactless wear free position sensor. This means maximum service life with the greatest-possible power delivery and its design prevents electromagnetic emissions (EMI) caused by brush sparking. The housing made of saltwater-resistant aluminum is HART-coat treated, meets the IP-67 standard for water and dust sealing and provides an integrated Sub-D connector (MIL spec. circular connector or cable gland on request). Brackets integrated in the housing for horizontal and vertical assembly. 8-fold, ball-bearing supported, steel gear train, drive shaft with ANSI multi-tooth.

The DA 30 series can be equipped with a standard PWM input (Pulse Width Modulation) that has two different interfaces: a differential, galvanic isolated interface (Opto-Coupler) and a single-ended interface with CMOS levels that is also used to program the servo parameters. It includes analog position feedback to detect the drive shaft position. A differential RS-422 PWM interface can be chosen instead of the opto-coupled interface.

The DA 30 with digital serial command interface (RS-485) receives its commands via a CRC secured protocol. It can return not only the shaft position in digital format, but also several diagnostic data such as the level of the supply voltage, current consumption and the temperature of the motor and electronics in digital form (optionally also the humidity within the actuator case). These kind of diagnostic capabilities help to determine the health state of the actuators before, during and after deployment.

Interface Options:

PWM-OPTO

PWM-Level Compatible, OPTO-coupler PWM Interface

PWM-TTL

PWM-Level Compatible, TTL PWM Interface

RS 422/TTL

RS 422-Level Compatible, Differential PWM Interface

RS 485 (2-wire)

RS-485 Compatible, Asynchronous Serial Command Interface

RS 485 Redundant

RS 485 Redundant Communication Interface and Redundant Power Supply

RS 485 (4-wire)

RS 485 Separated Receiver and Transmitter Lines for Interface A and B

For RS 485-Versions Only:

Customized commands can be implemented on request. Humidity sensor available.

2. Operating Data

		DA 30-30-5224...
Supply Voltage (rated)		28 V DC
Supply Voltage Range		24 ... 32 V DC
Standby Current ¹	at rated voltage	< 0.04 A
Rated Current ¹	at rated voltage	1.3 A
Peak Current ¹	at rated voltage	2.6 A
Rated Torque ¹	at rated speed	8.0 Nm (70.8 lbf-in)
Peak Torque ¹	at rated voltage	16.0 Nm (141.6 lbf-in)
No Load Speed ¹	at rated voltage	230 °/s
Rated Speed ¹	at rated torque	150 °/s
Default Travel Angle		±45° = 90° total travel
Max. Travel Angle ²		±85° = 170° total travel
Backlash (mechanical)		≤ 0.5°
Position Error under Temperature ³		≤ ±1.0°
Operating Temperature Range ⁴		-30°C ... +70°C (-22°F ... +158°F)
Storage Temperature Range		-55°C ... +85°C (-67°F ... +185°F)

- 1) Tolerance ±10%
- 2) Programming Tool # 985.4 for PWM-Versions required
- 3) -20°C ... +50°C , Δt = 70°C (-4°F ... +122°F , Δt = 126°F)
- 4) Low Temperature Modification (-70°C /-94°F) on request

3. Performance

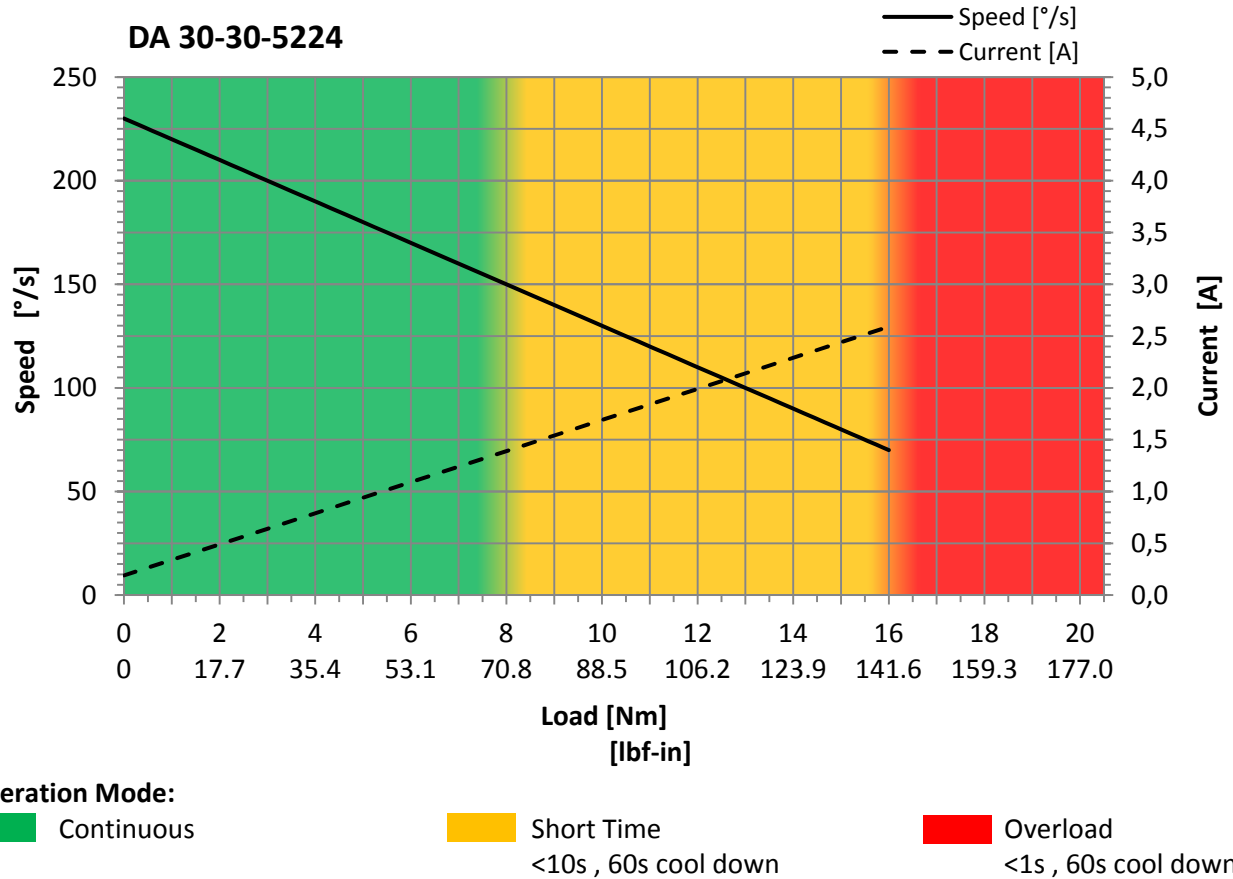

4. Command Signal

4.1. PWM Command Interface

PWM-OPTO/TTL , PWM-RS 422/TTL	DA 30-30-5224.1...	DA 30-30-5224.2...
Signal Voltage	TTL-Level HIGH: min. 3.5V , max. 5.5V TTL-Level LOW: min. 0.0V , max. 1.5V	
Frame Rate	2.6 ... 2000 ms	
Valid Pulse Lengths	0.9 ... 2.1 ms	
Pulse Lengths for Position Left / Center / Right	1.0 / 1.5 / 2.0 ms	
Resolution	≤ 1.0 μs	

4.2. RS 485 Command Signal

RS 485 , RS 485 Redundant	DA 30-30-5224.3...	DA 30-30-5224.4...	DA 30-30-5224.5...
Baud-Rate	115200 ±1.5% bits/s		
Protocol (Documentation available)	6 Byte (incl. 2 byte CRC)		

4.3. RS 485 Protocol Specifications

RS 485 , RS 485 Redundant	DA 30-30-5224.3...	DA 30-30-5224.4...	DA 30-30-5224.5...
Number of Data Bits	8		
Number of Stop Bits	1 or 2		
Parity	None		

Command / Response Frame

Byte #	Description
1	Command / Response-Code
2	Actuator ID
3	Argument 1
4	Argument 2
5	CRC High Byte
6	CRC Low Byte

4.4. Position Feedback Signal (PWM Versions)

The Position Feedback signal (Pos FB) is an analog output signal with a voltage value which is directly related to the output shaft's angular position. Reference is Supply Ground / Signal Ground (GND).

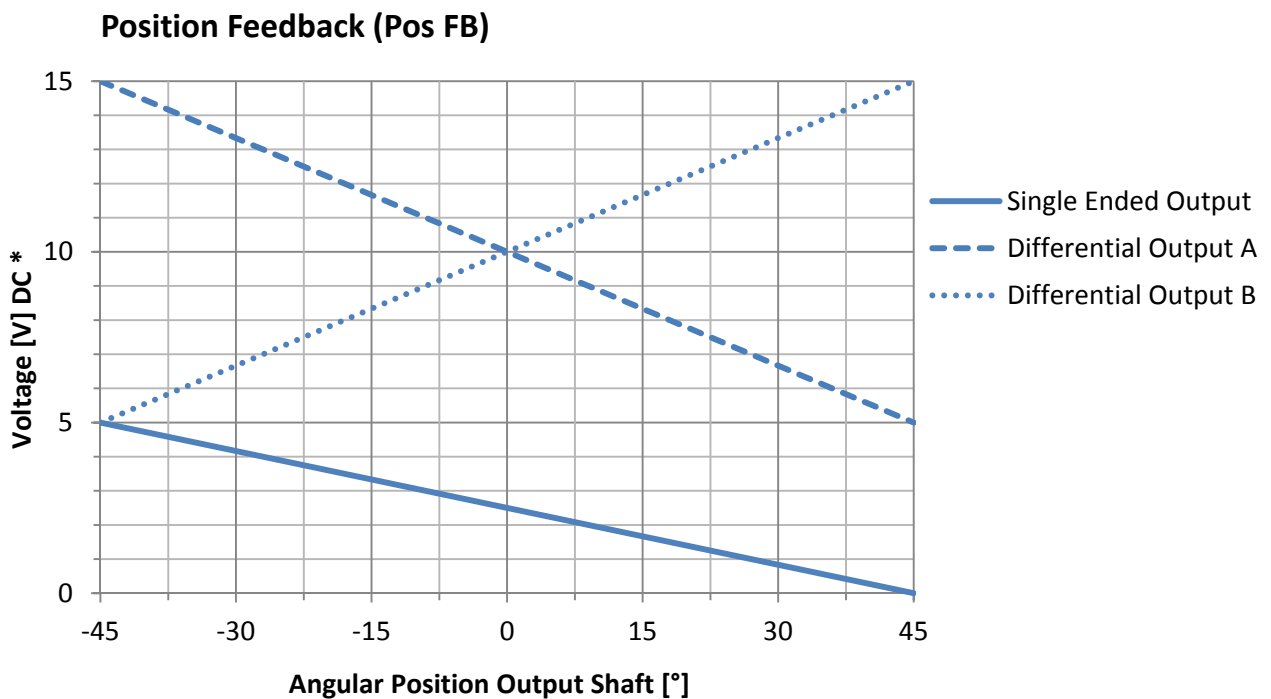
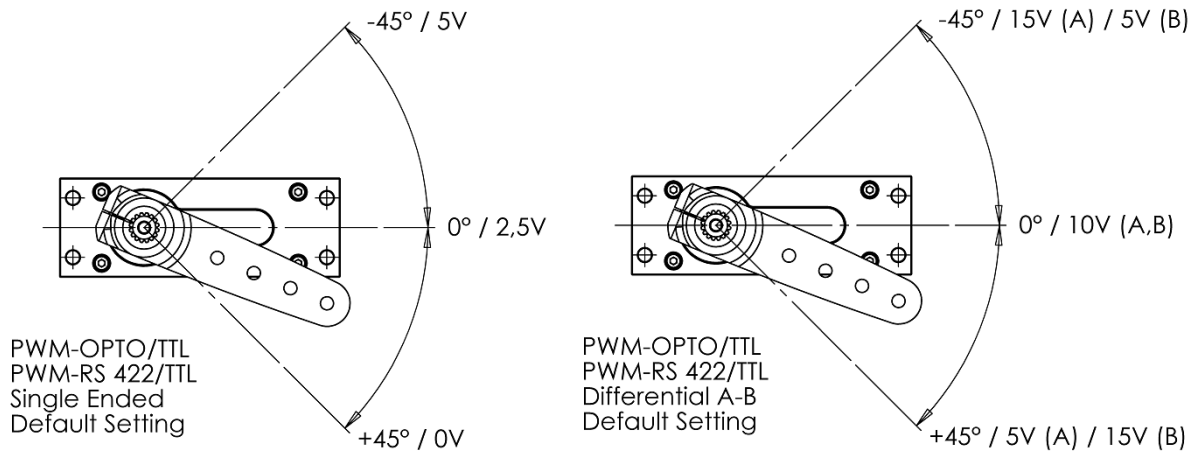

* Tolerance $\pm 5\%$

4.5. Position Feedback Value (RS 485 Versions)

Integrated in the RS 485 protocol a Position Feedback Value is available, representing the output shaft's angular position. Value readout by sending a request command. Detailed information is provided in the RS 485 documentation.

5. Materials and Protective Features

Case Material	Saltwater resistant Aluminum Alloy
Splash Water Resistance	IP 67 , waterproof to 1m depth
Case Surface Treatment	HART®-Coat
Salt Water Resistance	> 100 hrs. Salt Water Spray
Salt Water Resistance	Standard, Case Material
EMI / RFI Shielding	Case Shielding
Motor Type	Brushless DC Motor
Gear Set Material	Hardened Steel
Position Sensor	Contactless
Position Feedback	Standard
RS 485 Communication Interface	Optional
Humidity Sensor	Optional
Temperature Sensor ⁵	Standard , Motor and PCB

5) RS 485-Versions only

6. Dimensions

	DA 30-30-5224...
Case Dimensions	114.6 mm x 67.5 mm x 30.0 mm ±0.2 mm (4.512 in x 2.658 in x 1.181 in ±0.008 in)
Weight	640g (22.6oz) ±10%

6.1. Installation Dimensions

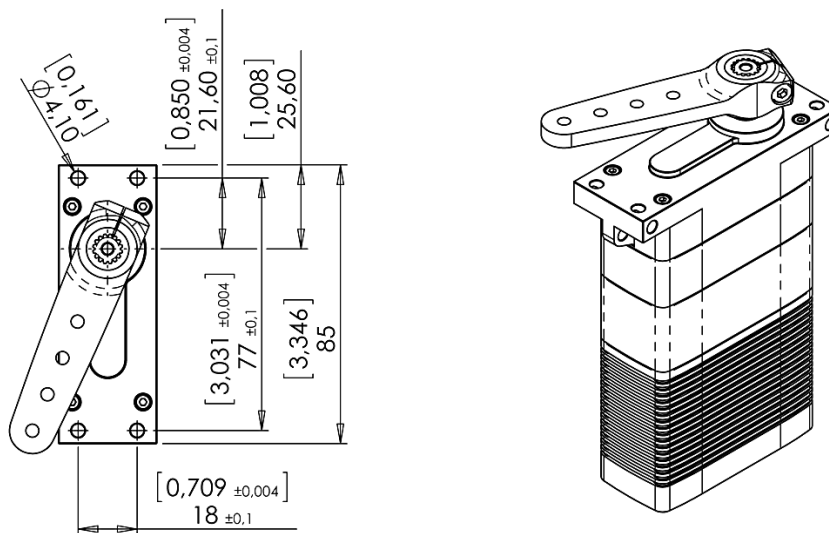
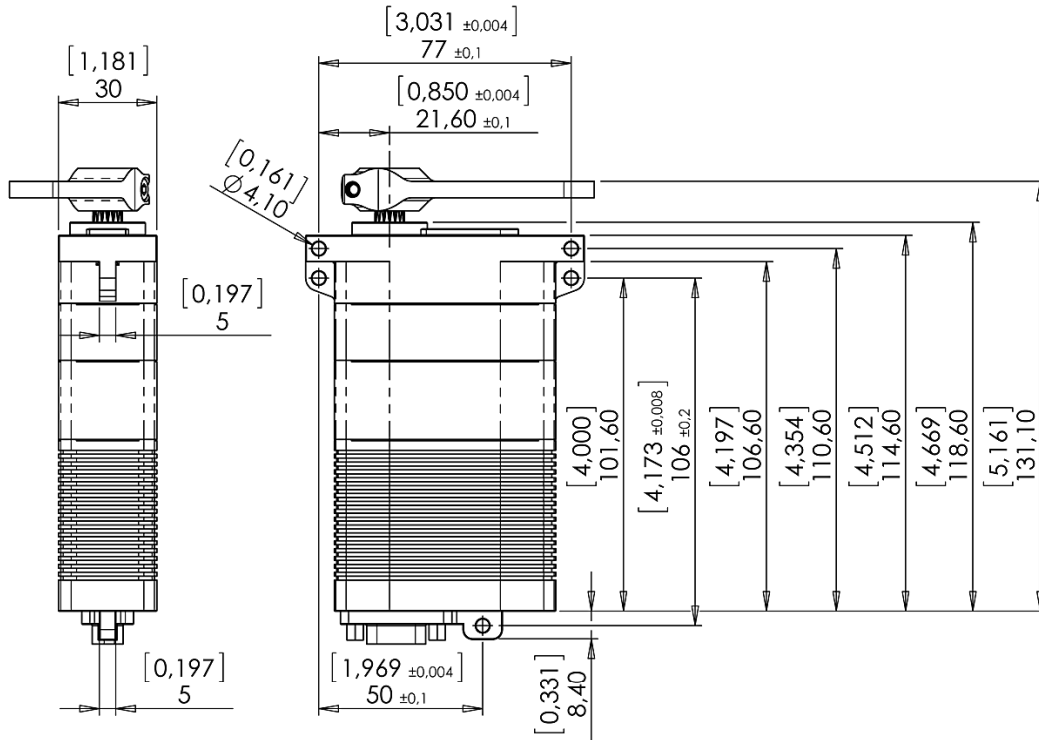

Not to scale

Dimensions [in] , mm

Content is subject to change without notice

Revision: B

6.2. Output Shaft Spline

Valid for all Interface Versions
 DA 30-30-5224._._

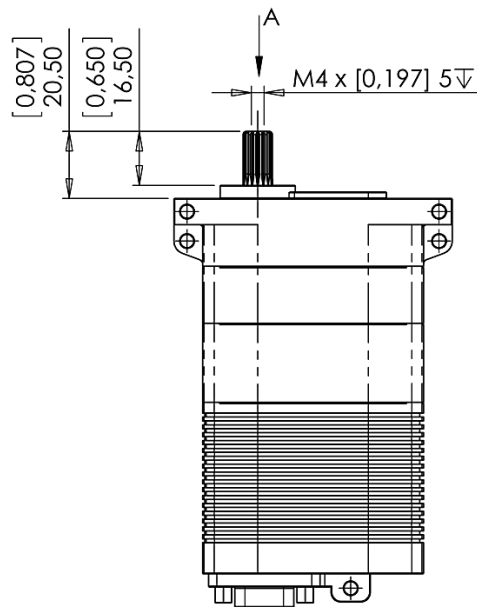

Output Shaft Spline:
 similar to DIN 867

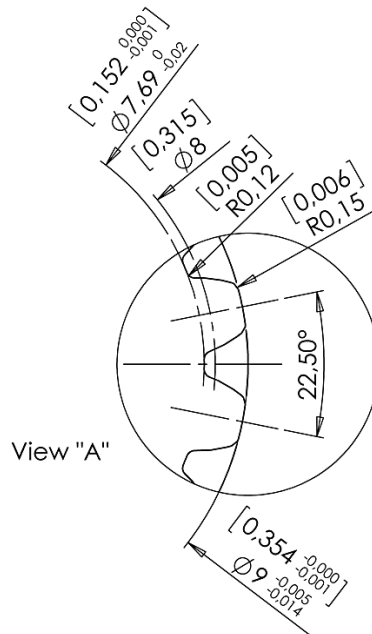

Not to scale

Dimensions [in] , mm

Content is subject to change without notice

Revision: B

7. Electrical Connection Options

PWM-OPTO Interface

Integrated Connector

Item # DA 30.30.5224.1._

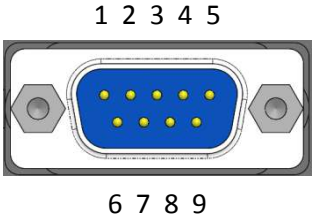
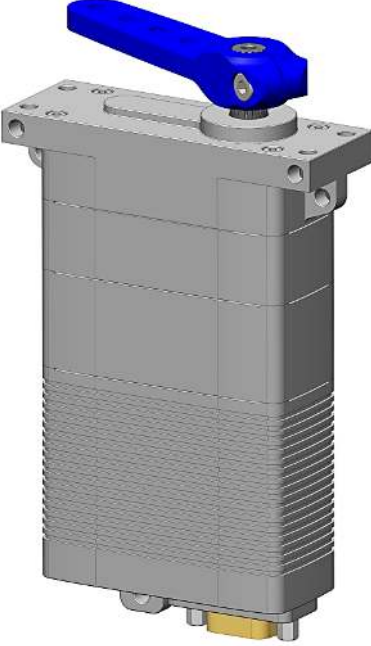
	Standard Connector		
	Manufacturer	ITT Cannon	
	Type	DEMM-9PE	
	Mating	D-SUB DE-9f	
	PWM-OPTO Pin Assignment		
	1	PWM (AO)	Command Signal, Anode Optocoupler
	2	PWM (CO)	Command Signal, Cathode Optocoupler
	3	Diff FB A	Differential Position Feedback Signal, Output A
	4	to Pin 7	Connect to Pin 7 (Supply Ground)
	5	Case GND	Case Ground
	6	+V DC	Supply Voltage
	7	GND	Supply Ground, Signal Ground
	8	Pos FB	Single Ended Position Feedback Signal
	9	Diff FB B	Differential Position Feedback Signal, Output B

NOTE:

Access to the actuator parameters is possible via the TTL-PWM-Interface only.
Programming Tool # 985.4 required.

PWM-TTL Interface

Integrated Connector

Item # DA 30.30.5224.1._

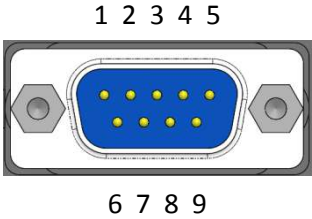
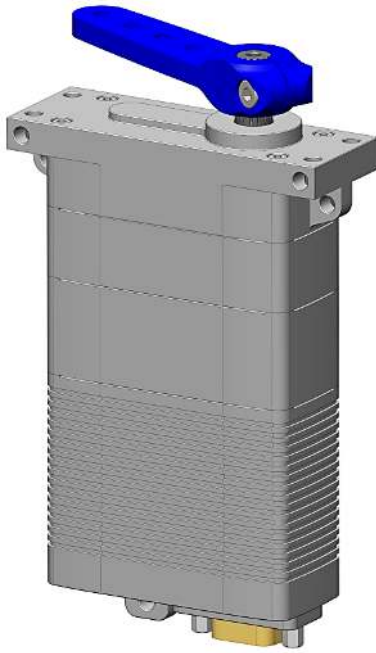
	Standard Connector		
	Manufacturer	ITT Cannon	
	Type	DEMM-9PE	
	Mating	D-SUB DE-9f	
	PWM-TTL Pin Assignment		
	1	NC	Do not connect
	2	NC	Do not connect
	3	Diff FB A	Differential Position Feedback Signal, Output A
	4	PWM	Command Signal
	5	Case GND	Case Ground
	6	+V DC	Supply Voltage
	7	GND	Supply Ground, Signal Ground
	8	Pos FB	Single Ended Position Feedback Signal
	9	Diff FB B	Differential Position Feedback Signal, Output B

NOTE:

Access to the actuator parameters is possible via the TTL-PWM-Interface only.
Programming Tool # 985.4 required.

PWM-RS 422/TTL Interface

Integrated Connector

Item # DA 30.30.5224.2_

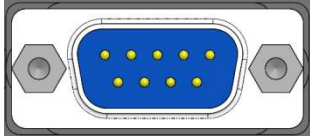
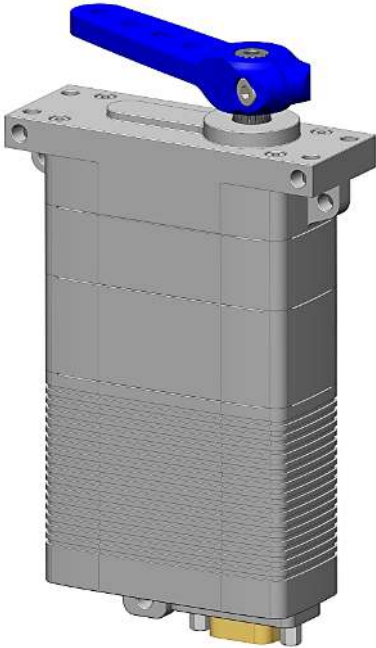
	Standard Connector		
	Manufacturer	ITT Cannon	
	Type	DEMM-9PE	
	Mating	D-SUB DE-9f	
	PWM-RS 422/TTL Pin Assignment		
	1	RS 422 / PWM	Non-Inverted RS 422-Input
	2	RS 422 / PWM	Inverted RS 422-Input
	3	Diff FB A	Position Feedback Signal, Output A
	4	TTL / PWM	Command and Parameter Input
	5	Case GND	Case Ground
	6	+V DC	Supply Voltage
7	GND	Supply Ground, Signal Ground	
8	Pos FB	Single Ended Position Feedback Signal	
9	Diff FB B	Differential Position Feedback Signal, Output B	

NOTE:

Access to the actuator parameters is possible via the TTL-PWM-Interface only.
Programming Tool # 985.4 required.

RS 485 Interface (2-wire)

Integrated Connector

Item # DA 30.30.5224.3_

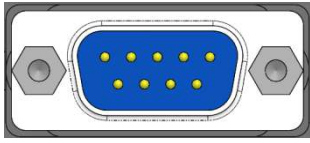
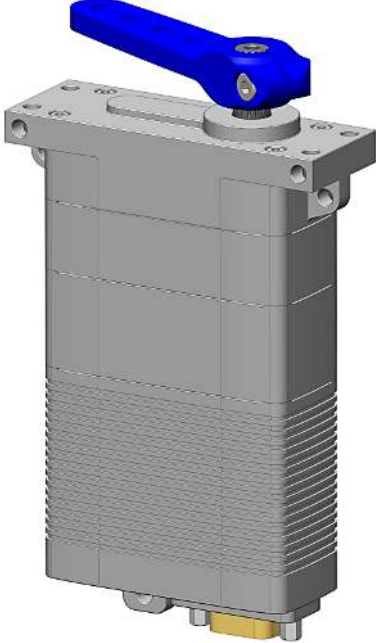
	Standard Connector	
Manufacturer	ITT Cannon	
Type	DEMM-9PE	
Mating	D-SUB DE-9f	
	RS 485 (2-wire) Pin Assignment	
1	RS 485 A	Non-Inverted Input/Output
2	RS 485 B	Inverted Input/Output
3	-	Do not connect
4	+V DC (2)	Supply Voltage, Secondary
5	Case GND	Case Ground
6	+V DC (1)	Supply Voltage, Primary
7	GND (1)	Supply Ground, Signal Ground, Primary
8	GND (2)	Supply Ground, Signal Ground, Secondary
9	-	Do not connect

RS 485 Redundant Interface

Integrated Connector

Item # DA 30.30.5224.4._

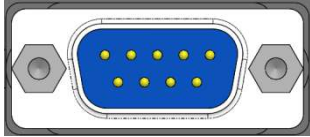
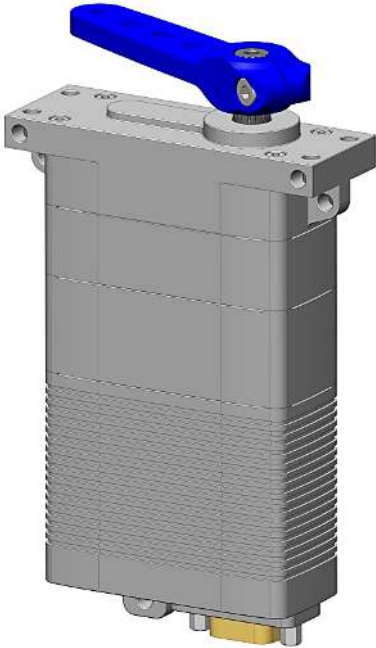
	Standard Connector		
	Manufacturer	ITT Cannon	
	Type	DEMM-9PE	
	Mating	D-SUB DE-9f	
	RS 485 Redundant Pin Assignment		
	1	RS 485 A (1)	Interface 1, Non-Inverted Input/Output
	2	RS 485 B (1)	Interface 1, Inverted Input/Output
	3	RS 485 A (2)	Interface 2, Non-Inverted Input/Output
	4	+V DC (2)	Supply Voltage, Secondary
	5	Case GND	Case Ground
	6	+V DC (1)	Supply Voltage, Primary
	7	GND (1)	Supply Ground, Signal Ground, Primary
	8	GND (2)	Supply Ground, Signal Ground, Secondary
	9	RS 485 B (2)	Interface 2, Inverted Input/Output

RS 485 Interface (4-wire)

Integrated Connector

Item # DA 30.30.5224.5_

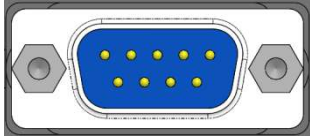
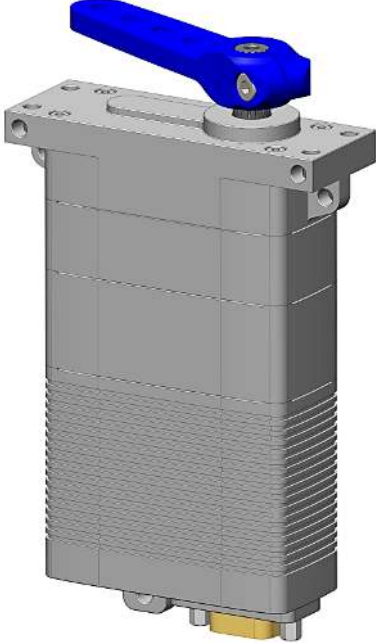
	Standard Connector		
	Manufacturer	ITT Cannon	
	Type	DEMM-9PE	
	Mating	D-SUB DE-9f	
	RS 485 (4-wire) Pin Assignment		
	1	RS 485 A (Rx)	Receiver, Non-Inverted, Input
	2	RS 485 B (Rx)	Receiver, Inverted, Input
	3	RS 485 A (Tx)	Transmitter, Non-Inverted, Output
	4	+V DC (2)	Supply Voltage, Secondary
	5	Case GND	Case Ground
	6	+V DC (1)	Supply Voltage, Primary
7	GND (1)	Supply Ground, Signal Ground, Primary	
8	GND (2)	Supply Ground, Signal Ground, Secondary	
9	RS 485 B (Tx)	Transmitter, Inverted, Output	

8. Accessories

Item	Item-No.
Aluminum Servo Arm	1941.21
Programming Tool PWM	985.4
Programming Tool RS-485	985.5

8.1. Aluminum Servo Arm

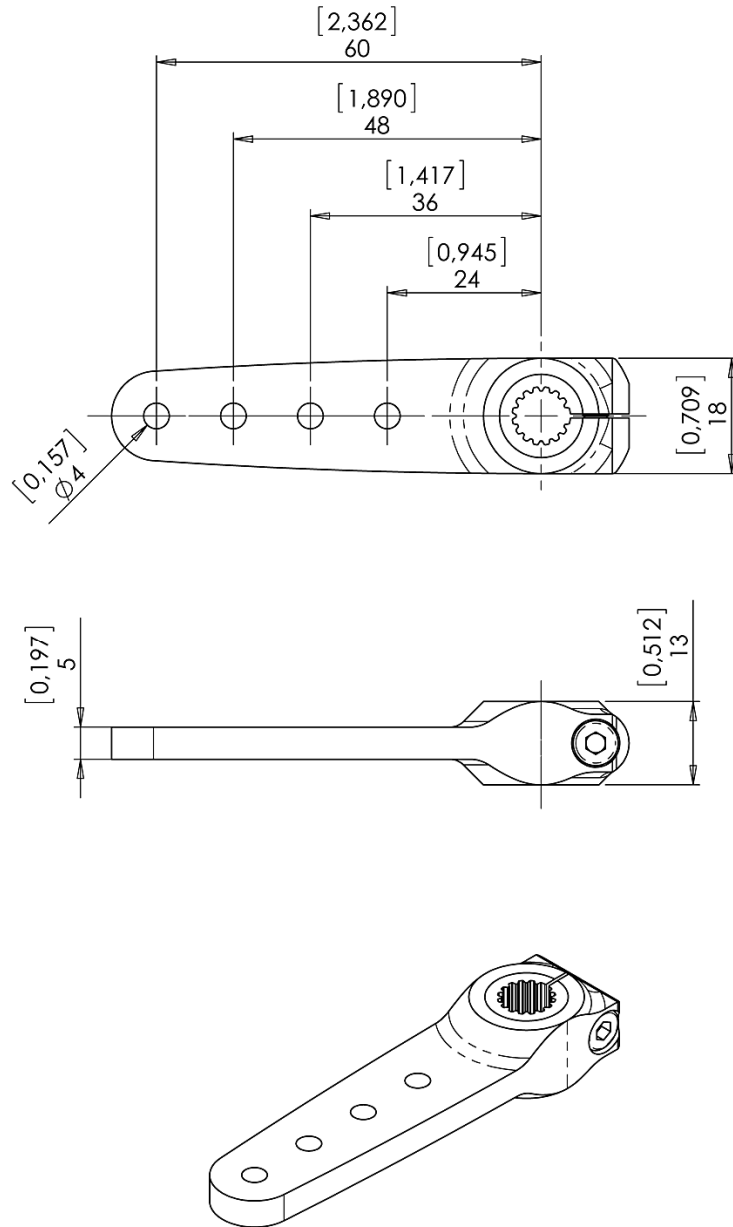

Not to scale

Dimensions [in] , mm

[Content is subject to change without notice](#)

Revision: B

9. Item Number System

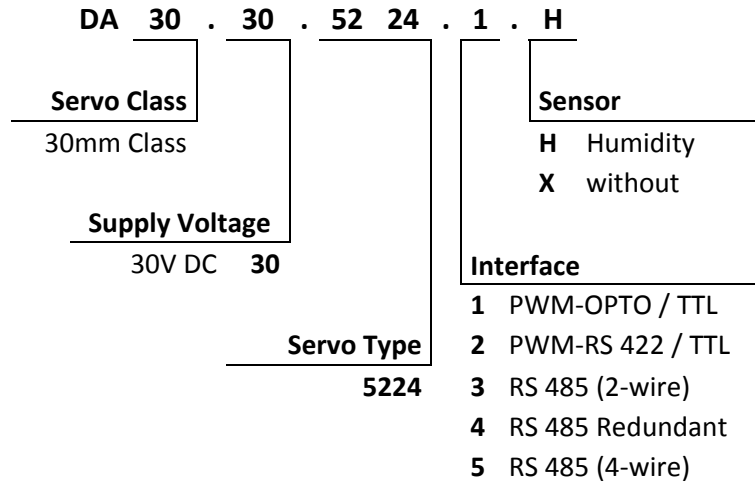

Volz Servos GmbH & Co. KG

Kaiserstrasse 15
63065 Offenbach
Germany
Tel. +49-69-985580-0
Fax +49-69-985580-40

e-Mail mail@volz-servos.com
Website www.volz-servos.com