

DA 26-R

Technical Specification

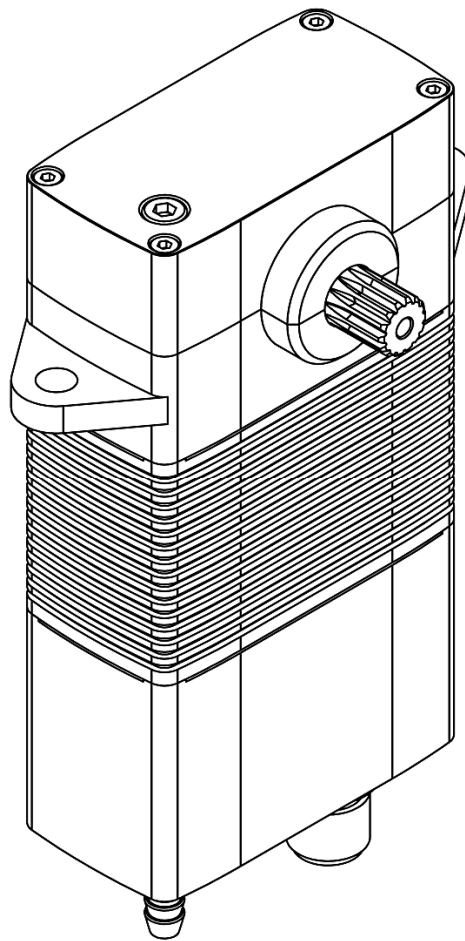

DA 26R-SUB-30-5024
DA 26R-AL-30-5024



Content

1. General Description	3
2. Operating Data	4
3. Performance	5
4. Command Signal	6
4.1. PWM Command Interface	6
4.2. RS 485 Command Signal	6
4.3. RS 485 Protocol Specifications	7
4.4. Position Feedback Signal (PWM Versions)	8
4.5. Position Feedback Value (RS 485 Versions).....	9
5. Materials and Protective Features	10
6. Dimensions	10
6.1. Installation Dimensions	11
6.2. Output Shaft Spline	12
7. Electrical Connection	13
8. Accessories	14
9. Item Number System.....	15

1. General Description

Based on our DA 26 actuator, we have developed a special underwater actuator for great depths.

The oil-filled actuators can be exposed to extreme pressure conditions. Customers have already deployed our DA 26R-30-5024 at depths down to 2000 m / 6600 feet.

To guarantee maximum safety and reliability, our DA 26R-30-5024 includes a brushless motor drive and a contactless, wear free rotary encoder. This ensures maximum service life with the greatest possible power delivery. The housing is CNC machined from marine bronze (DIN 1705 R65/MIL B24480); optionally, a variant made of HART®-coated, saltwater-resistant aluminum is also available that can be effectively used without an oil filling even above water.

A prominent feature is the 90° angled, self-locking output drive that is ideal for special linkages and which does not draw any current due to its self-locking with constant positioning under load! There is a hose adapter on the bottom of the housing for filling the actuator with oil after opening the venting screw.

The DA 26R-30-5024 series can be equipped with a standard PWM input (pulse width modulation) that has two different interfaces: a differential, galvanic isolated interface (opto-coupler) and a single-ended interface with CMOS levels that is also used to program the servo parameters. It includes analog position feedback to detect the drive shaft position. A differential RS-422 PWM interface can be chosen instead of the opto-coupled interface.

The DA 26R-30-5024 with digital serial command interface (RS-485) receives its commands via a CRC secured protocol. It can return not only the shaft position in digital format, but also several diagnostic data such as the level of the supply voltage, current consumption and the temperature of the motor and electronics in digital form (optionally also the humidity within the actuator case). These kind of diagnostic capabilities help to determine the health state of the actuators before, during and after deployment.

The fully programmable electronics of the DA 26R-30-5024 provides, for instance, protection against overloading and incorrect polarity.

Interface Options:

PWM-OPTO

PWM-Level Compatible, OPTO-coupler PWM Interface

PWM-TTL

PWM-Level Compatible, TTL PWM Interface

RS 422/TTL

RS 422-Level Compatible, Differential PWM Interface

RS 485 (2-wire)

RS-485 Compatible, Asynchronous Serial Command Interface

RS 485 Redundant

RS 485 Redundant Communication Interface and Redundant Power Supply

RS 485 (4-wire)

RS 485 Separated Receiver and Transmitter Lines for Interface A and B

2. Operating Data

Supply Voltage (rated)		28 VDC
Supply Voltage Range		12 ... 32 VDC
Standby Current ¹	at rated voltage	0.15 A
Rated Current ¹	at rated voltage	0.8 A
Peak Current ¹	at rated voltage	1.9 A
Rated Torque ¹	at rated speed	100 Ncm (142 ozf-in)
Peak Torque ¹	at rated voltage	200 Ncm (283 ozf-in)
No Load Speed ¹	at rated voltage	260 °/s
Rated Speed ¹	at rated torque	150 °/s
Default Travel Angle		±45° = 90° total travel
Max. Travel Angle ²		±85° = 170° total travel
Backlash (mechanical)		≤ 0.5°
Position Error under Temperature ³		≤ ±1.0°
Operating Temperature Range ⁴		-40°C ... +85°C (-40°F ... +185°F)
Storage Temperature Range		-55°C ... +95°C (-67°F ... +203°F)

- 1) Tolerance ±10%
- 2) Programming Tool # 985.4 for PWM-Versions required
- 3) -20°C ... +50°C , Δt = 70°C (-4°F ... +122°F , Δt = 126°F)
- 4) Low Temperature Modification on request

3. Performance

Servo performance strongly depends on the viscosity and temperature of the oil filling. Due to this reason a speed-to-current and speed-to-load relation can not be determined with general validity for all operation situations.

4. Command Signal

4.1. PWM Command Interface

PWM-OPTO/TTL	DA 26R-SUB-30-5024.1...	DA 26R-AL-30-5024.1...
Signal Voltage	TTL-Level HIGH: min. 3.5V , max. 5.5V TTL-Level LOW: min. 0.0V , max. 1.5V	
Frame Rate	2.6 ... 2000 ms	
Valid Pulse Lengths	0.9 ... 2.1 ms	
Pulse Lengths for Position Left / Center / Right	1.0 / 1.5 / 2.0 ms	
Resolution	≤ 1.0 μs	

4.2. RS 485 Command Signal

RS 485	DA 26R-SUB-30-5024.3...	DA 26R-AL-30-5024.3...
Baud-Rate	115200 ±1.5% bits/s	
Protocol (Documentation available)	6 Byte (incl. 2 byte CRC)	

4.3. RS 485 Protocol Specifications

RS 485	DA 26R-SUB-30-5024.3...	DA 26R-AL-30-5024.3...
Number of Data Bits	8	
Number of Stop Bits	1 or 2	
Parity	None	

Command / Response Frame

Byte #	Description
1	Command / Response-Code
2	Actuator ID
3	Argument 1
4	Argument 2
5	CRC High Byte
6	CRC Low Byte

4.4. Position Feedback Signal (PWM Versions)

The Position Feedback signal (Pos FB) is an analog output signal providing a voltage value which is directly related to the output shaft's angular position. Reference is Supply Ground / Signal Ground (GND).

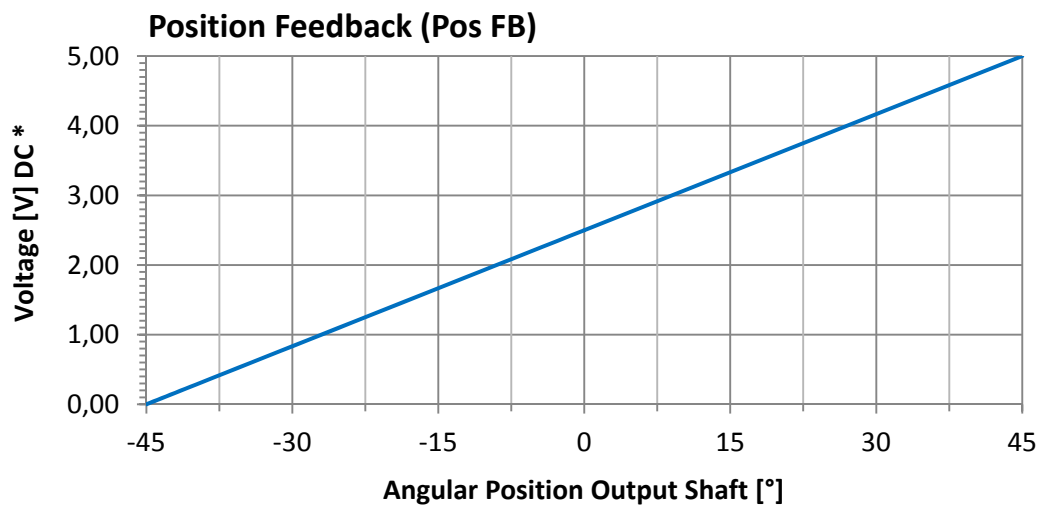
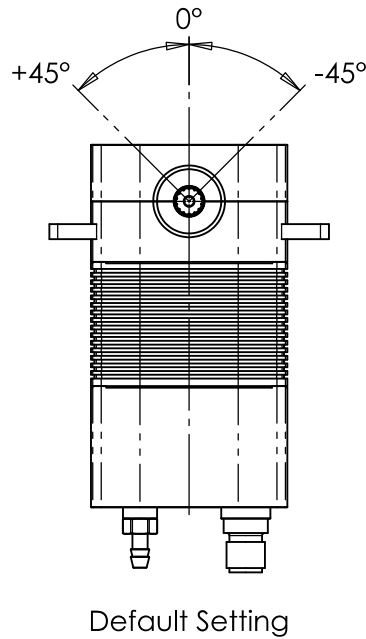

* Tolerance $\pm 5\%$

4.5. Position Feedback Value (RS 485 Versions)

Integrated in the RS 485 protocol a Position Feedback Value is available, representing the output shaft's angular position. Value readout by sending a request command. Detailed information is provided in the RS 485 documentation.

5. Materials and Protective Features

	DA 26R-SUB-30-5024-...	DA 26R-AL-30-5024-...
Case Material	Marine Bronze Alloy	Saltwater Resistant Aluminum Alloy
Case Surface Treatment	None	HART®-Coat
Splash Water Resistance / Pressure Resistance	With Oil Filling	IP 67, waterproof to 1m depth
Salt Water Resistance	Case Material	
EMI / RFI Shielding	Case Shielding	
Motor Type	Brushless DC Motor	
Gear Set	Hardened Steel	
Position Sensor	Contactless	
Position Feedback	Standard	

6. Dimensions

	DA 26R-SUB-30-5024-...	DA 26R-AL-30-5024-...
Case Dimensions	74.0 mm x 96.0 mm x 26.0 mm ±0.2 mm (2.913 in x 3.780 in x 1.024 in ±0.008 in)	
Weight	460g (16.3oz) ±10%	240g (8.4oz) ±10%

6.1. Installation Dimensions

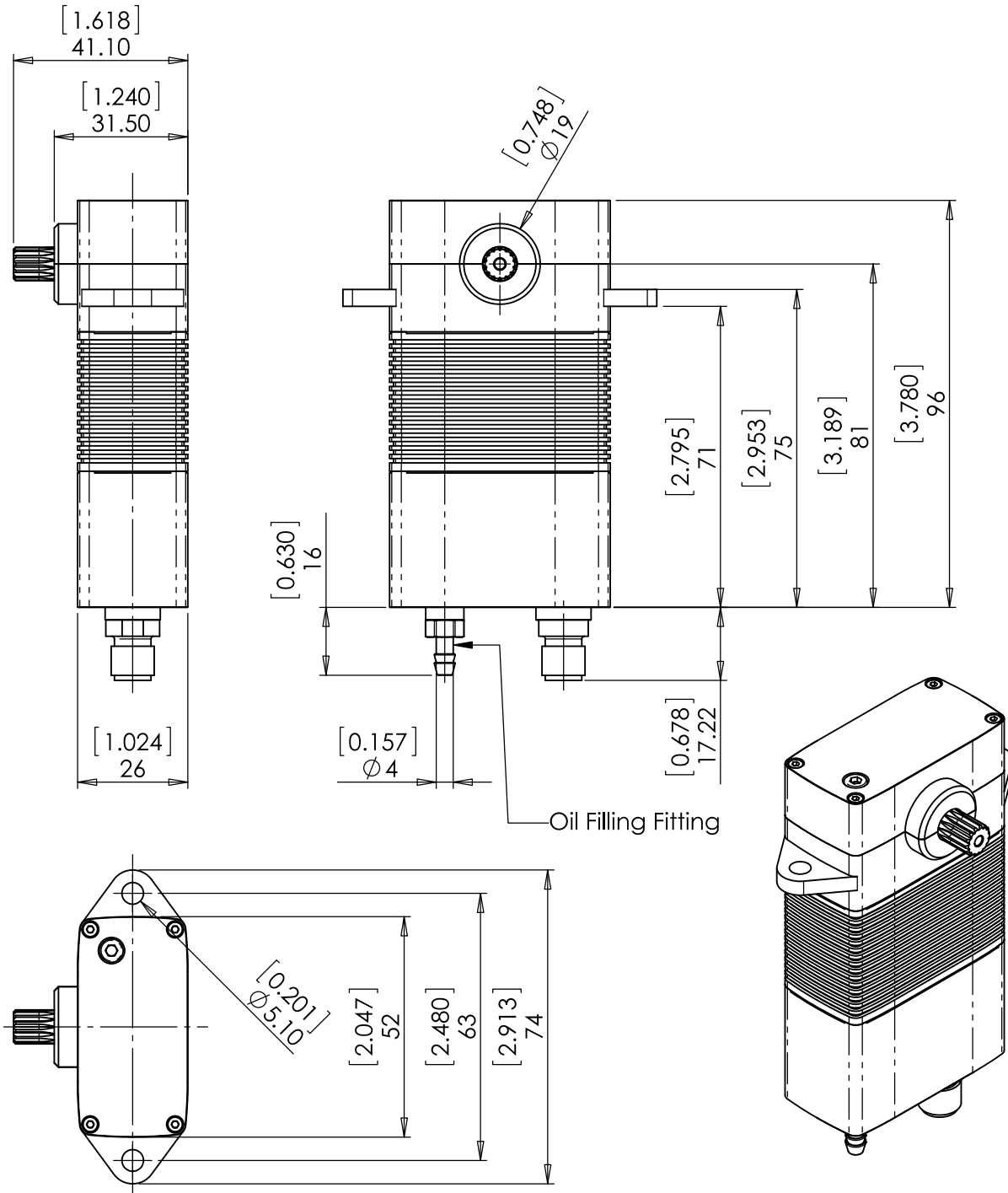

Not to scale

Dimensions [in] , mm

Content is subject to change without notice

6.2. Output Shaft Spline

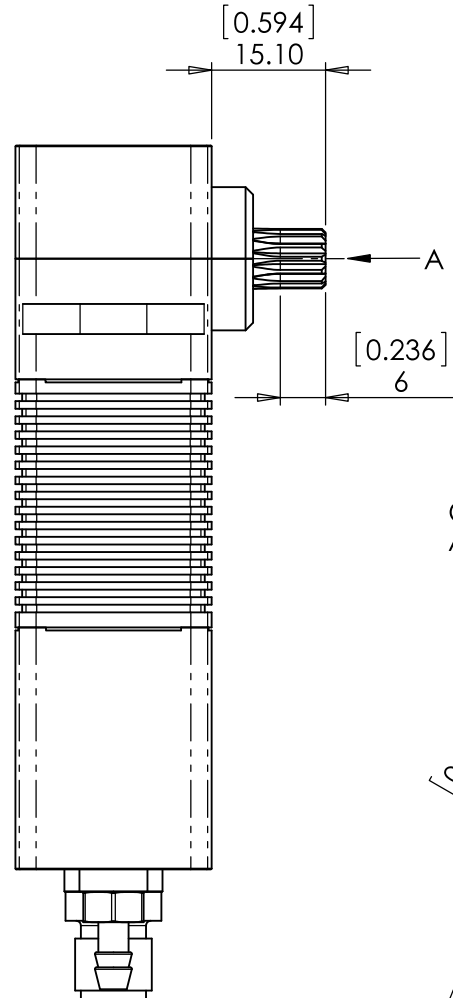

Output Shaft Spline:
ANSI B92.1-1996 fillet root side fit

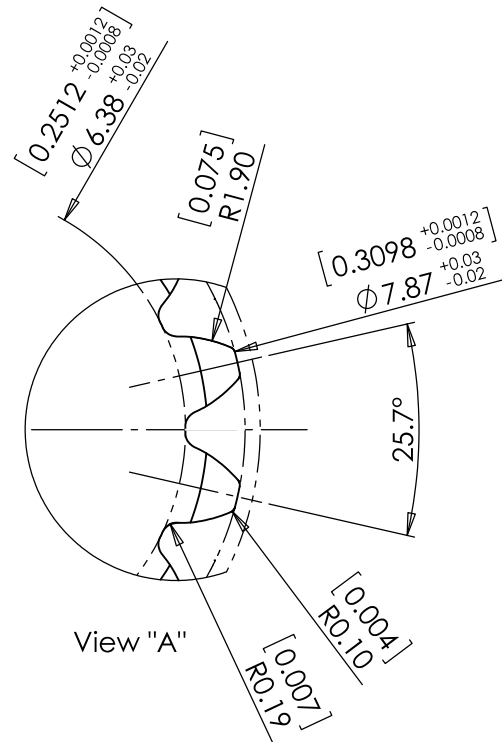

Not to scale

Dimensions [in] , mm

Content is subject to change without notice

7. Electrical Connection

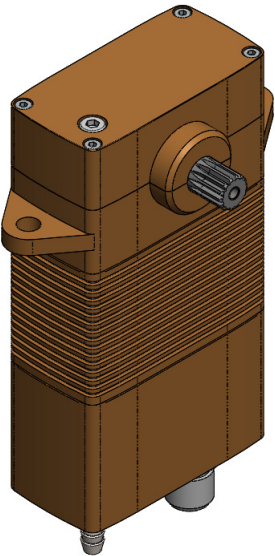
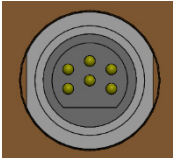
	Standard Connector		
	4 6 5  1 3 2	Manufacturer	Impulse Enterprises Inc.
		Type	IE55-1206 BCR
		Mating	IE55-1206 CCP
	TTL-PWM Pin Assignment		
	1	+V DC	Supply Voltage
	2	Pos FB	Position Feedback Signal
	3	GND	Supply & Signal Ground
	4	SIG	PWM Command Signal
	5	NC	Do not connect
6	NC	Do not connect	
RS 485 (2-wire) Pin Assignment			
1	+V DC	Supply Voltage	
2	RS 485 B	Inverting RS 485 Input / Output (A)	
3	RS 485 A	Non-Inverting RS 485 Input / Output (B)	
4	GND	Supply Ground, Signal Ground	
5	NC	Do not connect	
6	NC	Do not connect	

Other signal interfaces / pin assignments on request:
Opto-Coupled PWM, RS 422-PWM, RS 485 Redundant, RS 485 4-Wire

8. Accessories

Item	Item-No.
Programming Tool PWM	985.4
Programming Tool RS-485	985.5

All accessories to be purchased separately.

9. Item Number System

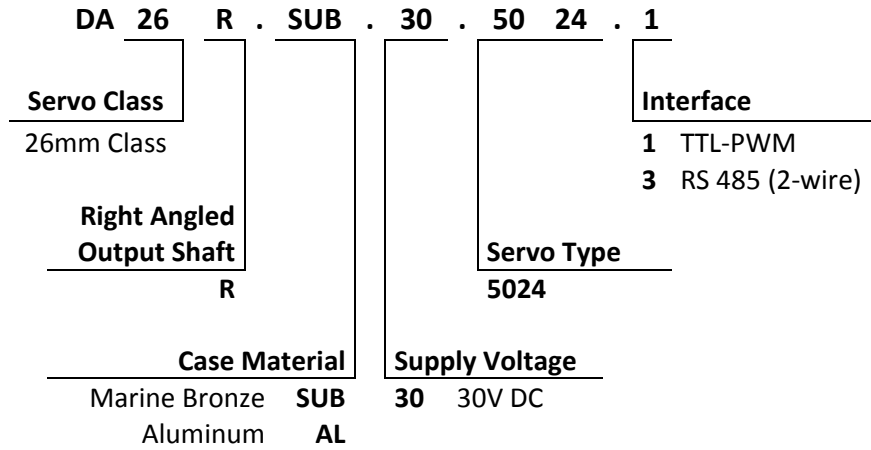

Volz Servos GmbH & Co. KG

Kaiserstrasse 15
63065 Offenbach
Germany
Tel. +49-69-985580-0
Fax +49-69-985580-40

e-Mail mail@volz-servos.com
Website www.volz-servos.com