

## DA 22-SUB Technical Specification

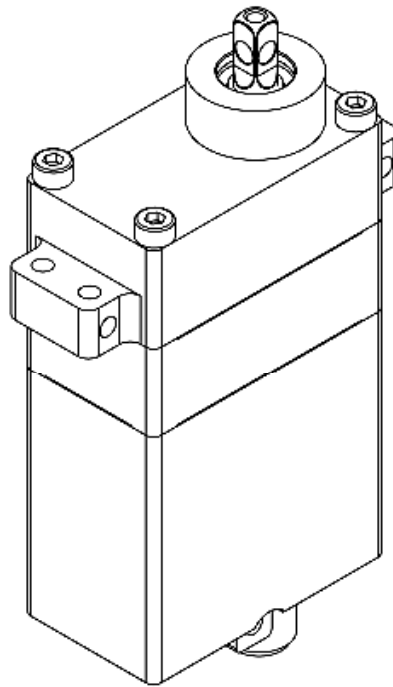

DA 22-SUB-30-4128



## Content

1.	General Description .....	3
2.	Operating Data .....	4
3.	Performance .....	5
4.	Command Signal .....	6
4.1.	PWM Command Signal .....	6
4.2.	RS 485 Command Signal .....	6
4.3.	Position Feedback Signal .....	7
4.4.	Position Feedback Value.....	8
5.	Materials and Protective Features .....	9
6.	Dimensions .....	9
6.1.	Installation Dimensions .....	10
6.2.	Installation Dimensions .....	11
6.3.	Output Shaft Dimensions .....	12
7.	Electrical Connection Options .....	13
8.	Accessories .....	15
9.	Item Number System.....	16

## 1. General Description

We developed the submersible DA 22-SUB, which based on the DA 22 actuator. The DA 22-SUB is pressure proof down to a depth of 100 meters (300ft / 10 bar / 145 psi).

The housing is CNC machined from marine bronze (DIN 1705 R65/MIL B24480). The integrated overload clutch (ISS system) protects the solid-steel gear train from every kind of radial shock loads.

The standard version (PWM) of the DA 22-SUB comes equipped with analog position feedback and an integrated moisture or temperature sensor. Every actuator is tested in our test lab for six hours in a pressure tank under various atmospheric pressures (0 to 15 bar).

## 2. Operating Data

		DA 22-SUB-30-4128...
Supply Voltage (rated)		28 V DC
Supply Voltage Range		20 ... 30 V DC
Standby Current <sup>1</sup>	at rated voltage	< 0.04 A
Rated Current <sup>1</sup>	at rated voltage	0.3 A
Peak Current <sup>1</sup>	at rated voltage	0.6 A
Rated Torque <sup>1</sup>	at rated speed	180 Ncm (255 ozf-in)
Peak Torque <sup>1</sup>	at rated voltage	300 Ncm (424 ozf-in)
No Load Speed <sup>1</sup>	at rated voltage	180 °/s
Rated Speed <sup>1</sup>	at rated torque	110 °/s
Default Travel Angle		±45° = 90° total travel
Max. Standard Travel Angle <sup>2</sup>		±85° = 170° total travel
Extended Travel Angle (optional)		±165° = 330° total travel
Backlash (mechanical)		≤ 0.5°
Position Error under Temperature <sup>3</sup>		≤ ±1.0°
Operating Temperature Range		-30°C ... +70°C (-22°F ... +158°F)
Storage Temperature Range		-35°C ... +80°C (-31°F ... +176°F)

1) Tolerance ±10%

2) Programming Tool # 985.3 (PWM) resp. # 985.8 (RS 485) required

3) -20°C ... +50°C , Δt = 70°C (-4°F ... +122°F , Δt = 126°F)

### 3. Performance

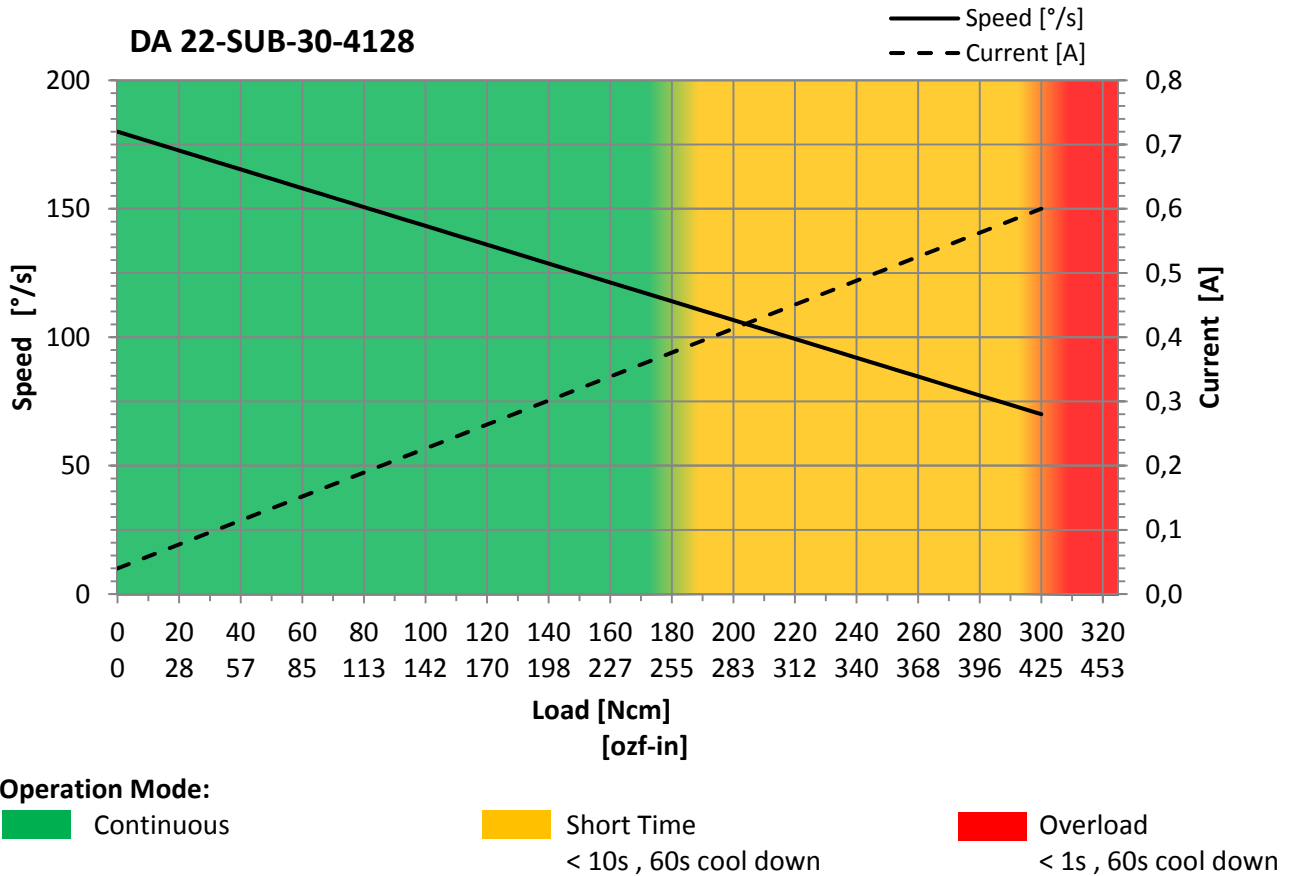

## 4. Command Signal

### 4.1. PWM Command Signal

Valid for all Versions with PWM Command Signal

PWM	DA 22-SUB-30-4128._.P._.X.ST_
Signal Voltage	TTL-Level HIGH: min. 3.5V , max. 5.5V TTL-Level LOW: min. 0.0V , max. 1.5V
Frame Rate	2.6 ... 2000 ms
Valid Pulse Lengths	0.9 ... 2.1 ms
Pulse Lengths for Position Left / Center / Right	1.0 / 1.5 / 2.0 ms
Resolution	≤ 1.0 μs

### 4.2. RS 485 Command Signal

Valid for all Versions with RS 485 Command Signal

RS 485	DA 22-SUB-30-4128._.X._.R.ST_
Baud-Rate	115200 ±1.5% bits/s
Protocol (Documentation available)	6 Byte (incl. 2 byte CRC)

### 4.3. Position Feedback Signal

The Position Feedback signal (Pos FB) is an analog output signal with a voltage value which is directly related to the output shaft's angular position. Reference is Supply Ground (GND).

**Available Versions:**

- PWM Command Signal , Pos FB and Humidity Sensor (DA 22-SUB-30-4128.\_.P.\_.H.X.ST\_)
- PWM Command Signal , Pos FB and Temperature Sensor (DA 22-SUB-30-4128.\_.P.\_.T.X.ST\_)

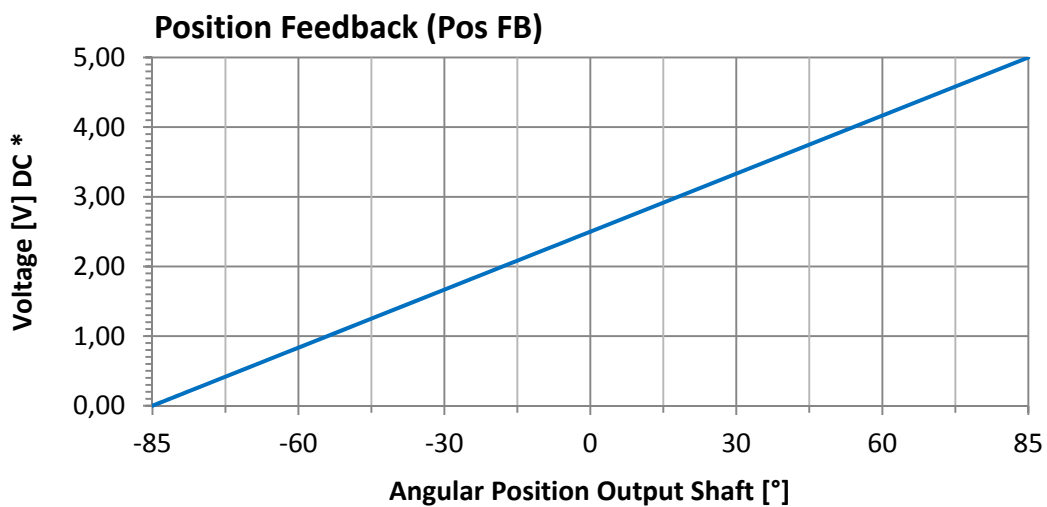
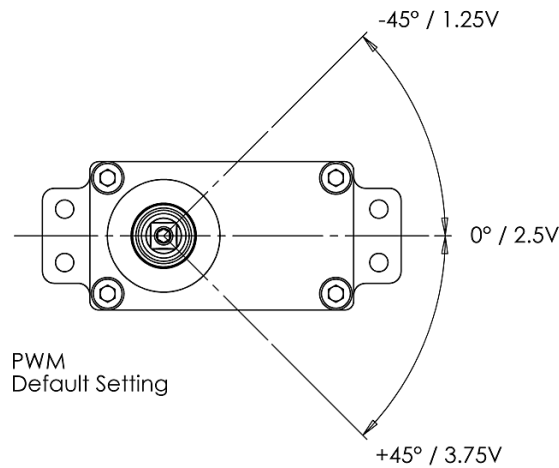

\* Tolerance ±5%

## 4.4. Position Feedback Value

Integrated in the RS 485 protocol a Position Feedback Value is available, representing the output shaft's angular position. Value readout by sending a request command. Detailed information is provided in the RS 485 documentation.



## 5. Materials and Protective Features

Case Material	Saltwater resistant Marine Bronze
Splash Water Resistance	Pressure-Resistance 100m (300ft) Water Depth
Salt Water Resistance	Case Material
EMI / RFI Shielding	Case Shielding
Motor Type	Brushed DC Motor
Gear Set Material	Hardened Steel
Position Sensor	Precision Potentiometer
ISS Gear Protection System	Optional
Position Feedback	Optional
Extended Travel Angle	Optional
Humidity- or Temperature Sensor <sup>4</sup>	Standard
RS 485 Communication Interface	Optional

- 4) Either Humidity or Temperature Sensor in PWM-Version available  
No Humidity or Temperature Sensor in RS 485-Version available

## 6. Dimensions

	DA 22-SUB-30-4128...
Case Dimensions	44.5 mm x 80.5 mm x 25.0 mm ±0.2 mm (1.752 in x 3.169 in x 0.984 in ±0.008 in)
Weight *	372g (13.1 oz) ±10%

## 6.1. Installation Dimensions

Connector Side Entry  
 DA 22.SUB.30.4128.\_.P.\_.\_.STS

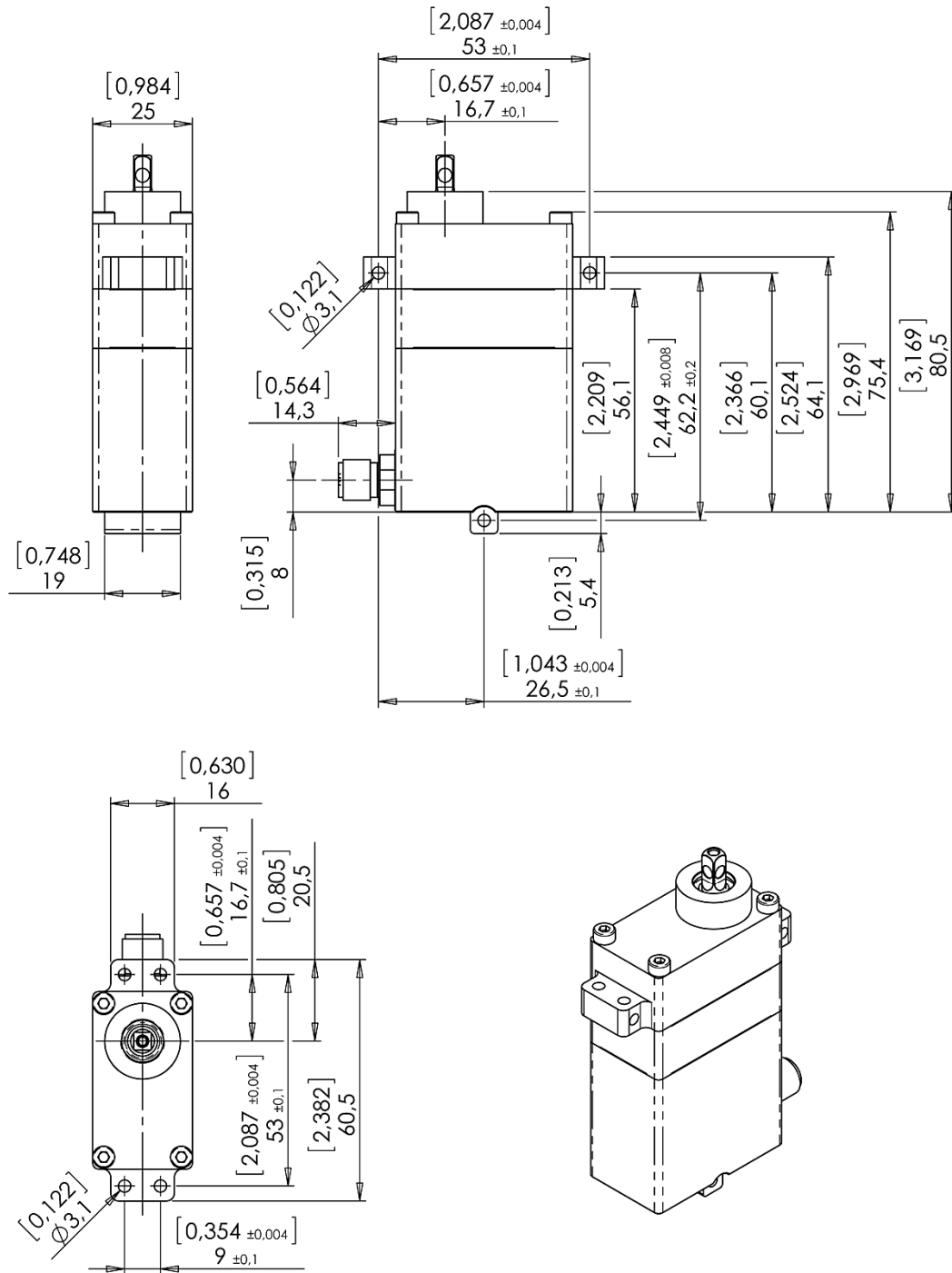

Not to scale

Dimensions [in] , mm

Content is subject to change without notice

Revision: B

## 6.2. Installation Dimensions

Connector Bottom Entry  
DA 22.SUB.30.4128.\_.P.\_.\_.STB

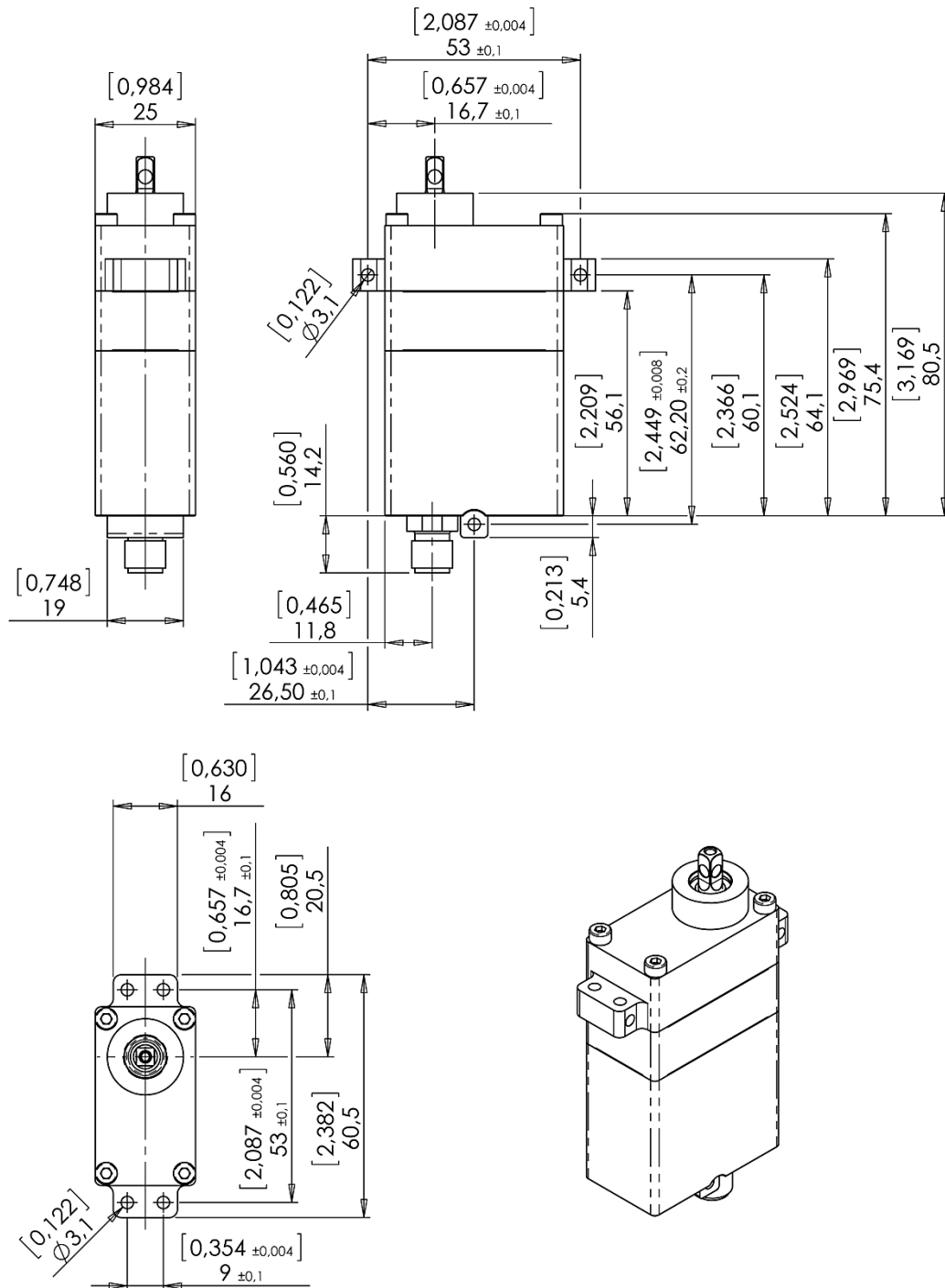

Not to scale

Dimensions [in] , mm

Content is subject to change without notice

Revision: B

### 6.3. Output Shaft Dimensions

Valid for all Versions  
DA 22.SUB.30.4128...

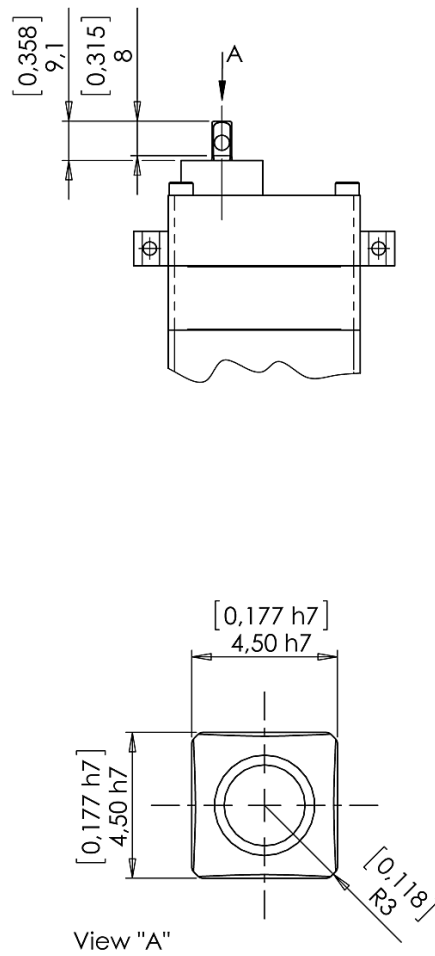

Not to scale

Dimensions [in] , mm

[Content is subject to change without notice](#)

Revision: B

## 7. Electrical Connection Options

Integrated Connector  
Side Entry

Item # DA 22.SUB.30.4128.\_.P.\_.\_.STS

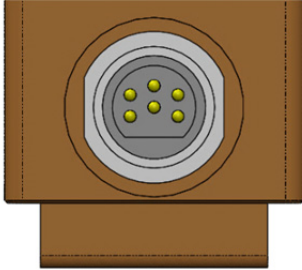
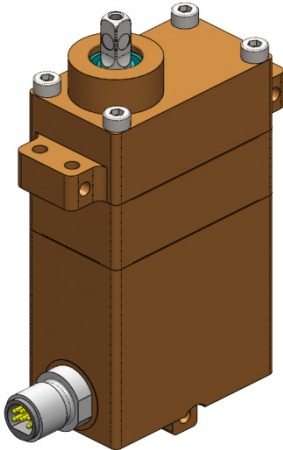
	<b>Side Entry Connector</b>	
	Manufacturer	Impulse Enterprise Inc.
Type	IE55-1206-BCR	
Mating	IE55-1206-CCP/UT , IE55-1206-CCP R/A	
<b>PWM Pin Assignment</b>		
1	<b>+V DC</b>	Supply Voltage
2	<b>Pos FB</b>	Position Feedback Signal
3	<b>GND</b>	Supply Ground, Signal Ground
4	<b>SIG</b>	Command Signal
5	<b>NC</b>	Do not connect
6	<b>NC</b>	Do not connect
<b>RS 485 Pin Assignment</b>		
1	<b>+V DC</b>	Supply Voltage
2	<b>RS 485 A</b>	Non Inverting RS 485 Input / Output (A)
3	<b>GND</b>	Supply Ground, Interface Ground
4	<b>RS 485 B</b>	Inverting RS 485 Input / Output (B)
5	<b>NC</b>	Do not connect
6	<b>NC</b>	Do not connect
		

Integrated Connector  
Bottom Entry

Item # DA 22.SUB.30.4128.\_.P.\_.\_.STB

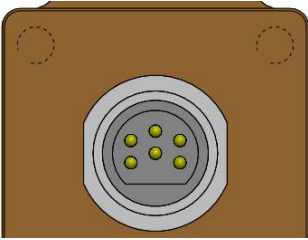
	<b>Bottom Entry Connector</b>	
	Manufacturer	Impulse Enterprise Inc.
Type	IE55-1206-BCR	
Mating	IE55-1206-CCP/UT , IE55-1206-CCP R/A	
<b>PWM Pin Assignment</b>		
1	<b>+V DC</b>	Supply Voltage
2	<b>Pos FB</b>	Position Feedback Signal
3	<b>GND</b>	Supply Ground, Signal Ground
4	<b>SIG</b>	Command Signal
5	<b>NC</b>	Do not connect
6	<b>NC</b>	Do not connect
<b>RS 485 Pin Assignment</b>		
1	<b>+V DC</b>	Supply Voltage
2	<b>RS 485 A</b>	Non Inverting RS 485 Input / Output (A)
3	<b>GND</b>	Supply Ground, Interface Ground
4	<b>RS 485 B</b>	Inverting RS 485 Input / Output (B)
5	<b>NC</b>	Do not connect
6	<b>NC</b>	Do not connect

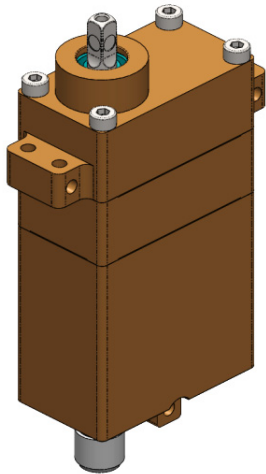

## 8. Accessories

Item	Item-No.
Programming Tool PWM	985.3
Programming Tool RS-485	985.8

## 9. Item Number System

DA	22	SUB	30	41	28	I	P	E	H	R	STS
<b>Servo Class</b> 22mm Class		<b>Submersible</b> SUB		<b>Supply Voltage</b> 30 V DC 30		<b>Servo Type</b> 4128		<b>Electrical Connection</b> STS Standard Connector, Side Entry STB Standard Connector, Bottom Entry			
								<b>Command Interface</b> R RS 485 X PWM			
								<b>Sensor</b> H Humidity (PWM-Version) T Temperature (PWM) X without (RS 485-Version)			
								<b>Extended Travel Angle</b> E integrated X without			
								<b>Position Feedback</b> P integrated			
								<b>ISS Gear Protection System</b> I integrated X without			



### Volz Servos GmbH & Co. KG

Kaiserstrasse 15  
63065 Offenbach  
Germany  
Tel. +49-69-985580-0  
Fax +49-69-985580-40

e-Mail [mail@volz-servos.com](mailto:mail@volz-servos.com)  
Website [www.volz-servos.com](http://www.volz-servos.com)