

DA 15-N

Technical Specification

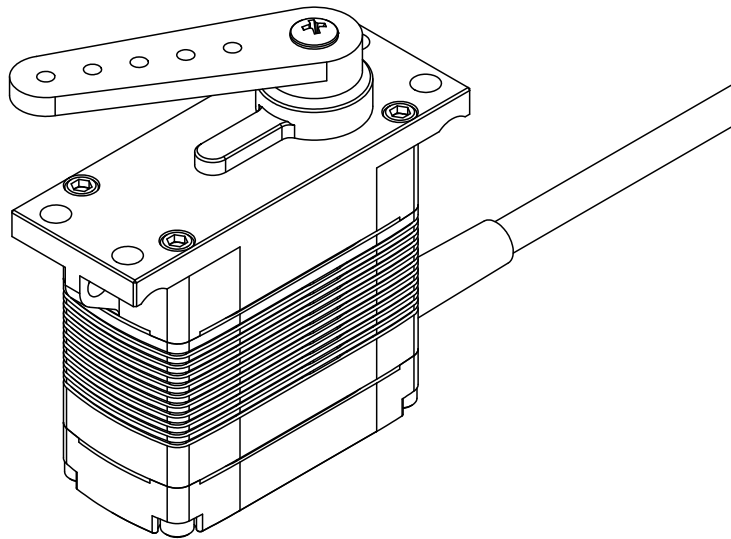

DA 15-N-06-BLDC-250

DA 15-N-12-BLDC-250



Content

1. General Description	3
2. Operating Data.....	4
3. Performance	5
4. Command Signal	7
4.1. Position Feedback Signal	7
5. Materials and Features	8
6. Dimensions	8
6.1. Installation Dimensions	9
6.2. Output Shaft Spline	10
7. Electrical Connection	11
8. Accessories.....	12
8.1. Aluminum Servo Arm, short	13
8.2. Aluminum Servo Arm, long.....	14
8.3. Aluminum Mounting Frame	15
9. Item Number System	16

1. General Description

The DA 15-N is our smallest and lightest full brushless actuator.

Its brushless motor and contactless, wear free position sensing system makes the DA 15-N immune to wear, vibrations and shock loads. It has especially been designed for the usage in harsh environments and for safety critical applications that require an actuator with high endurance. The conductive aluminum case and the shielded connection cable are reducing the susceptibility to any kind to EMI/RFI noise to the absolute minimum.

The servo is fully programmable.

Advantages of the full brushless actuator:

1. Maximized service life through vibration-resistant, brushless DC motor
2. Brushless motor technology eliminates the typical electromagnetic noise of brush-type motors and provides ultra-long endurance
3. Contactless, wear free position sensing system
4. Aluminum housing with minimal weight and size in functional design
5. The saltwater-resistant, HART-coat treated aluminum housing withstands at least 100 hours of saltwater spray without damage and meets the IP-67 standard for water and dust protection
6. Excellent immunity to any kind of electromagnetic noise achieved with aluminum housing, low electromagnetic emissions through brushless motor
7. Several programming possibilities, e.g. overload protection of the internal electric brushless motor, which allows to reduce the motor current if the motor is being overloaded

2. Operating Data

	DA 15-N-06-...	DA 15-N-12-...	DA 15-N-12-...
Supply Voltage (rated)	6 VDC	12 VDC	14 VDC
Supply Voltage Range	5 ... 9 VDC	10 ... 16 VDC	10 ... 16 VDC
Standby Current ¹ at rated voltage	0.05 A	0.05 A	0.05 A
Rated Current ¹ at rated voltage	0.5 A	0.35 A	0.35 A
Peak Current ¹ at rated voltage	1.5 A	0.85 A	0.95 A
Rated Torque ¹ at rated speed	16 Ncm (22.7 ozf-in)	25 Ncm (35.4 ozf-in)	25 Ncm (35.4 ozf-in)
Peak Torque ¹ at rated voltage	60 Ncm (85 ozf-in)	60 Ncm (85 ozf-in)	60 Ncm (85 ozf-in)
No Load Speed ¹ at rated voltage	290 °/s	330 °/s	390 °/s
Rated Speed ¹ at rated torque	235 °/s	240 °/s	290 °/s
Default Travel Angle	±45° = 90° total travel		
Max. Travel Angle ²	±90° = 180° total travel		
Backlash (mechanical)	≤ 0.5°		
Position Error under Temperature ³	≤ ±1.0°		
Operating Temperature Range ⁴	-30°C ... +70°C (-22°F ... +158°F)		
Storage Temperature Range	-35°C ... +80°C (-31°F ... +176°F)		

- 1) Tolerance ±10%
- 2) Programming Tool # 985.3 required
- 3) -20°C ... +50°C , Δt = 70°C (-4°F ... +122°F , Δt = 126°F)
- 4) Low Temperature Modification on request

3. Performance

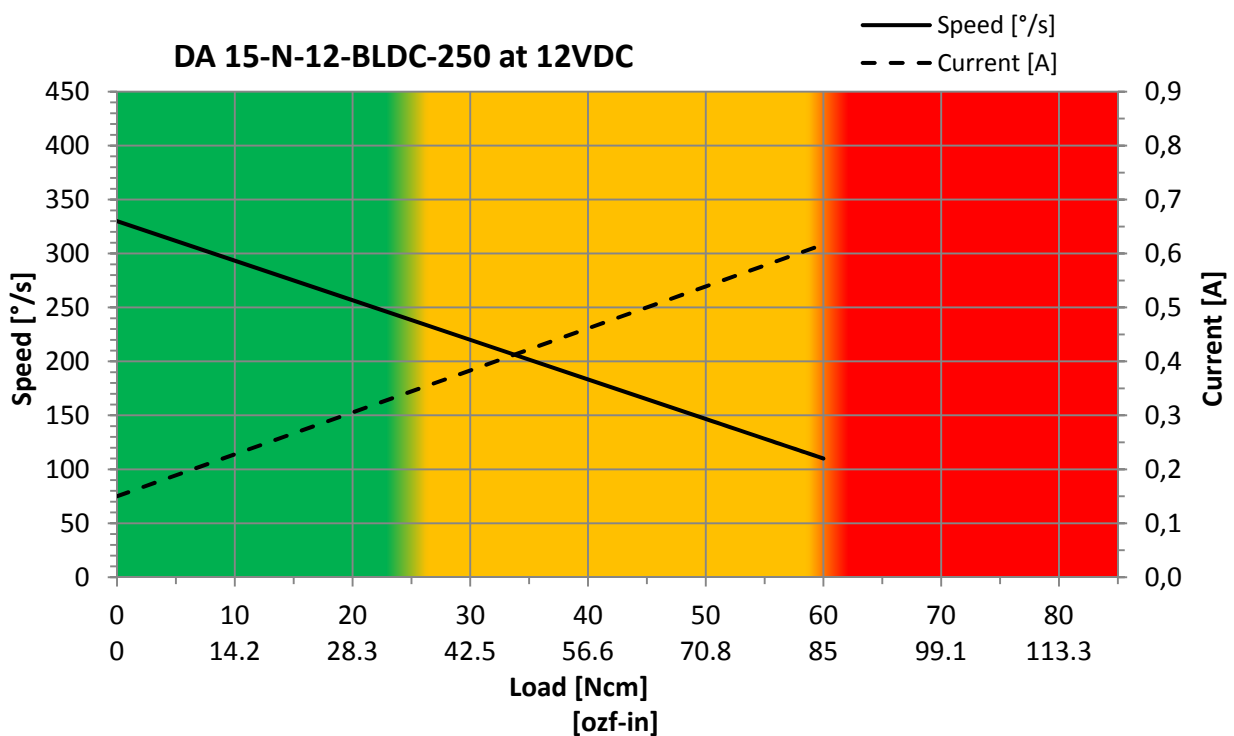
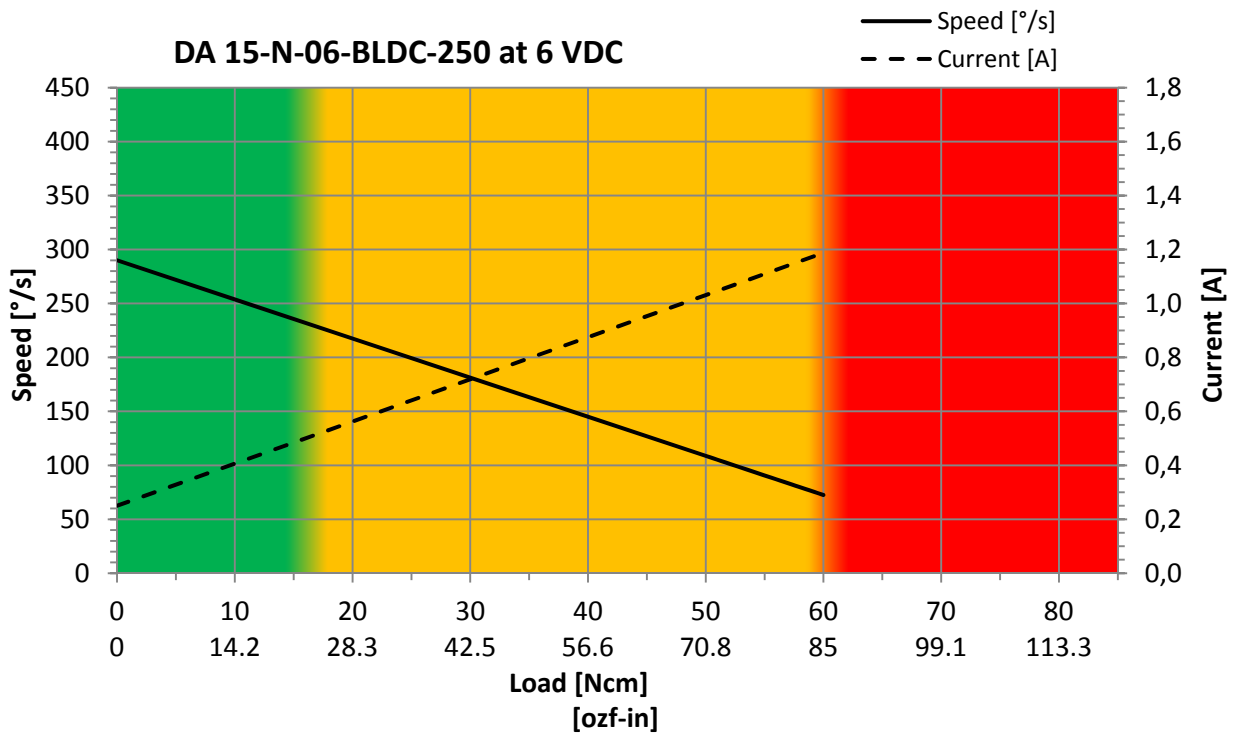

Operation Mode:

■ Continuous

■ Short Time
< 10s , 60s cool down

■ Overload
< 1s , 60s cool down

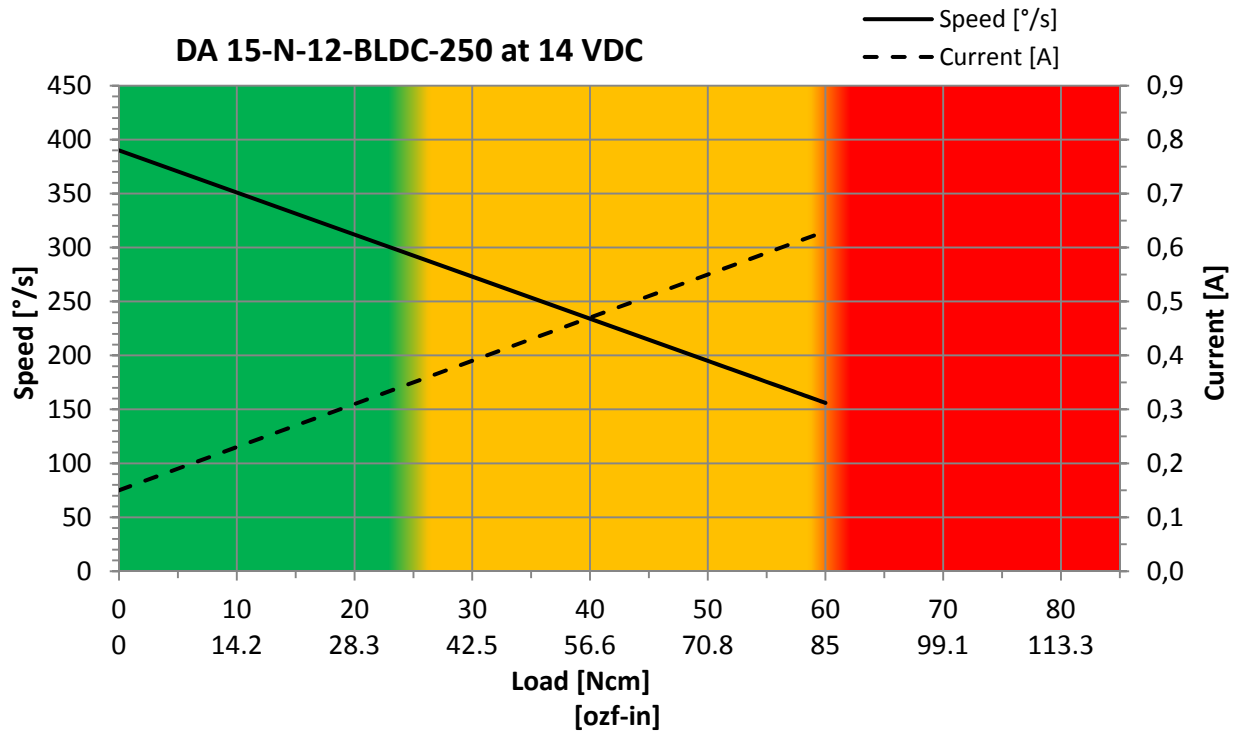

Operation Mode:
 Continuous

Short Time
 < 10s , 60s cool down

Overload
 < 1s , 60s cool down

4. Command Signal

PWM Signal Voltage	TTL-Level HIGH: min. 3.5 V, max. 5.5 V TTL-Level LOW: min. 0.0 V, max. 1.5 V
Frame Rate	2.6 ... 2000 ms
Valid Pulse Lengths	0.9 ... 2.1 ms
Pulse Length for Position Left / Center / Right	1.0 / 1.5 / 2.0 ms
Resolution	≤ 1 μs

4.1. Position Feedback Signal

The Position Feedback signal (Pos FB) is an analog output signal providing a voltage value which is directly related to the output shaft's angular position. Reference is Supply Ground / Signal Ground (GND).

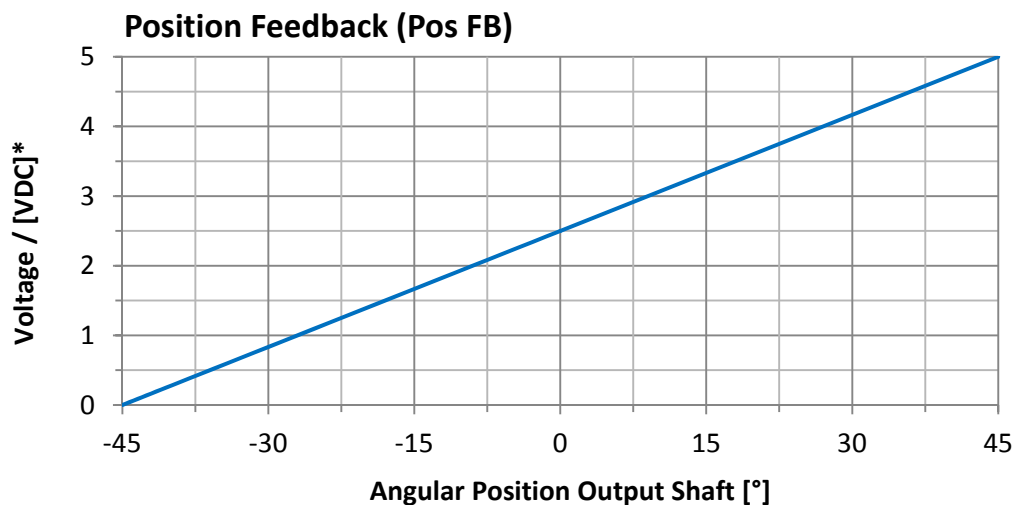
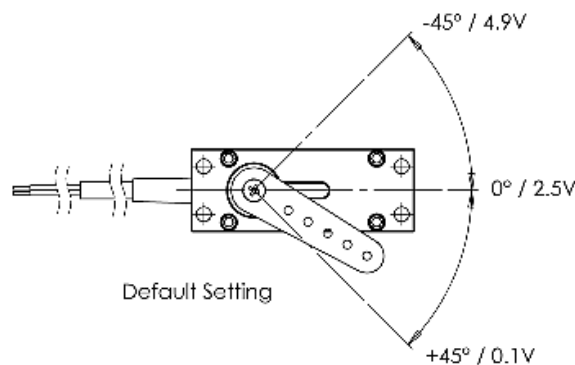

* Tolerance ±5%

5. Materials and Features

Case Material	Saltwater Resistant Aluminum Alloy
Case Surface Treatment	HART® - Coat
Splash Water Resistance	IP 67, waterproof to 1m depth
Salt Water Resistance	Case Material
EMI / RFI Shielding	Case Shielding
Motor Type	Brushless DC Motor
Gear Set Material	Hardened Steel
Position Sensor	Contactless
Position Feedback	Standard
Shielded Connecting Cable	Standard

6. Dimensions

Case Dimensions	29.4 mm x 39.4 mm x 14.6 mm ±0.2 mm (1.157 in x 1.551 in x 0.575 in ±0.008 in)
Weight	30g (1.06oz) ±10%

6.1. Installation Dimensions

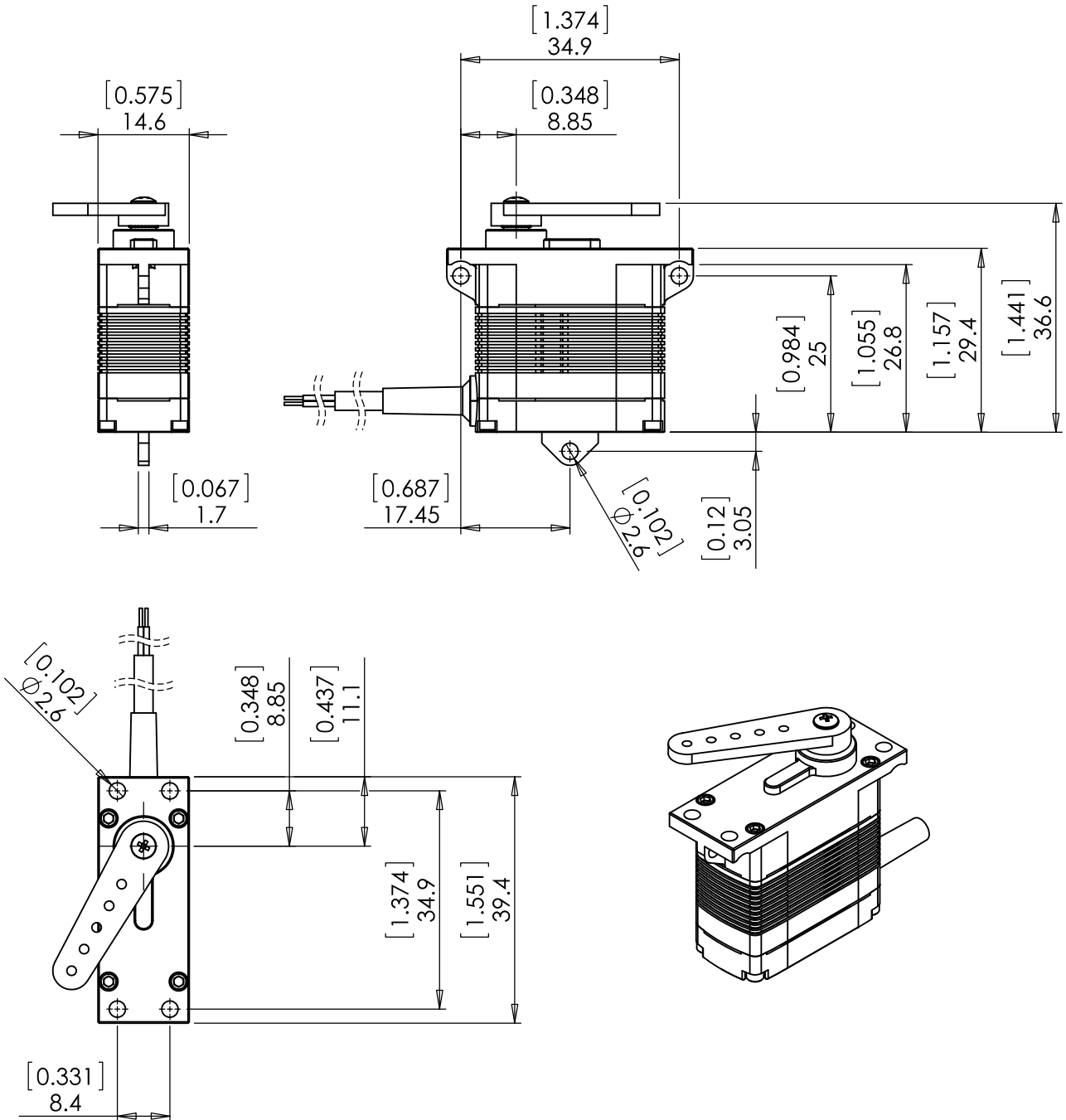

Not to scale

Dimensions: [in] , mm

Content is subject to change without notice

Revision: D

6.2. Output Shaft Spline

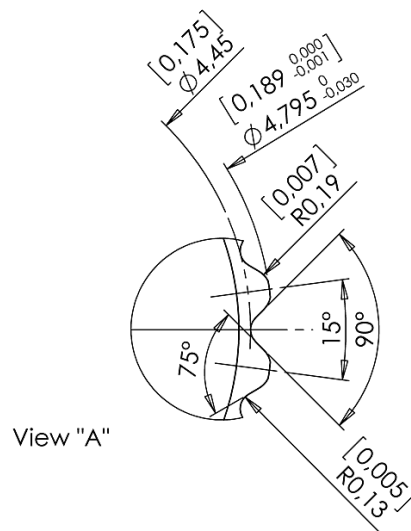
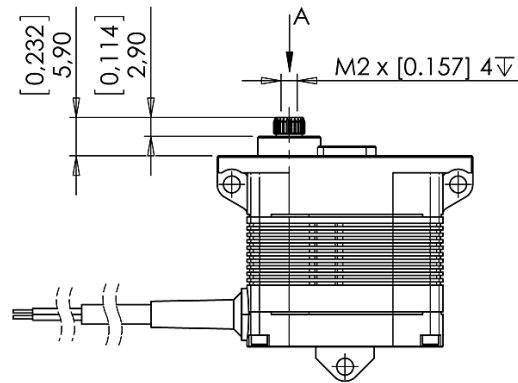



Not to scale

Dimensions: [in] , mm

Content is subject to change without notice

Revision: D

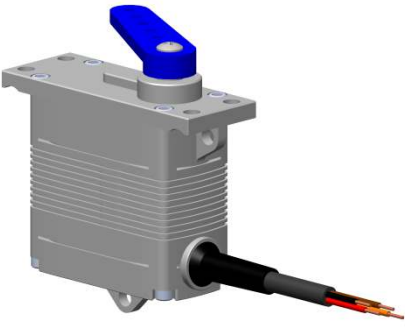
7. Electrical Connection

			Shielded Cable		
			Description	Flexible shielded cable	
			Type	LifYDY-UL	
			Wire Gauge	4x AWG 28 (4x 0.08 mm ²)	
	Pin Assignment				
	1	Red	+VDC	Supply Voltage	
	2	Black	GND	Supply Ground, Signal Ground	
3	Orange	SIG	PWM Command Signal		
4	Brown	Pos FB	Position Feedback		

8. Accessories

Item	Item-No.
Aluminum Servo Arm, short, single sided	1521.21
Aluminum Servo Arm, long, single sided	1521.22
Aluminum Mounting Frame	1521.31 incl. screws
Programming Tool	985.3

All accessories to be purchased separately.

8.1. Aluminum Servo Arm, short

1521.21

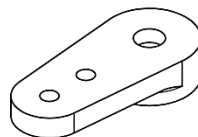
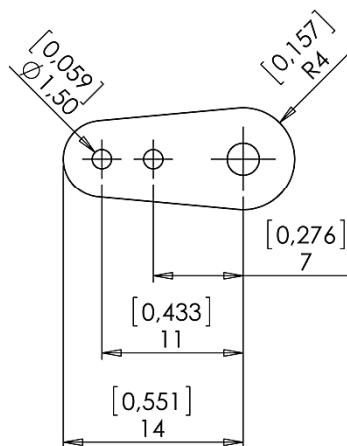
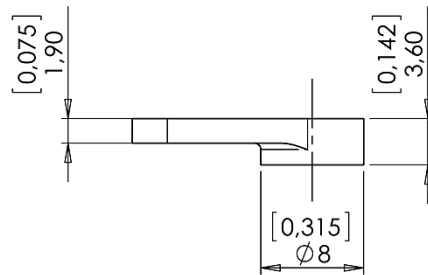

Not to scale

Dimensions: [in] , mm

Content is subject to change without notice

Revision: D

8.2. Aluminum Servo Arm, long

1521.22

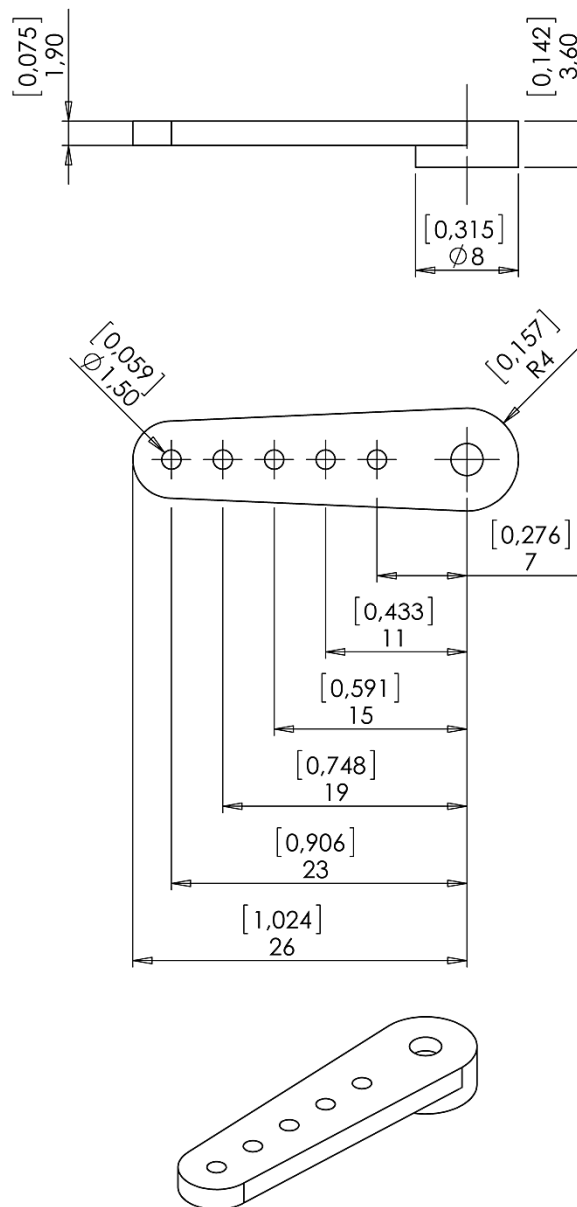

Not to scale

Dimensions: [in] , mm

Content is subject to change without notice

Revision: D

8.3. Aluminum Mounting Frame

1521.31

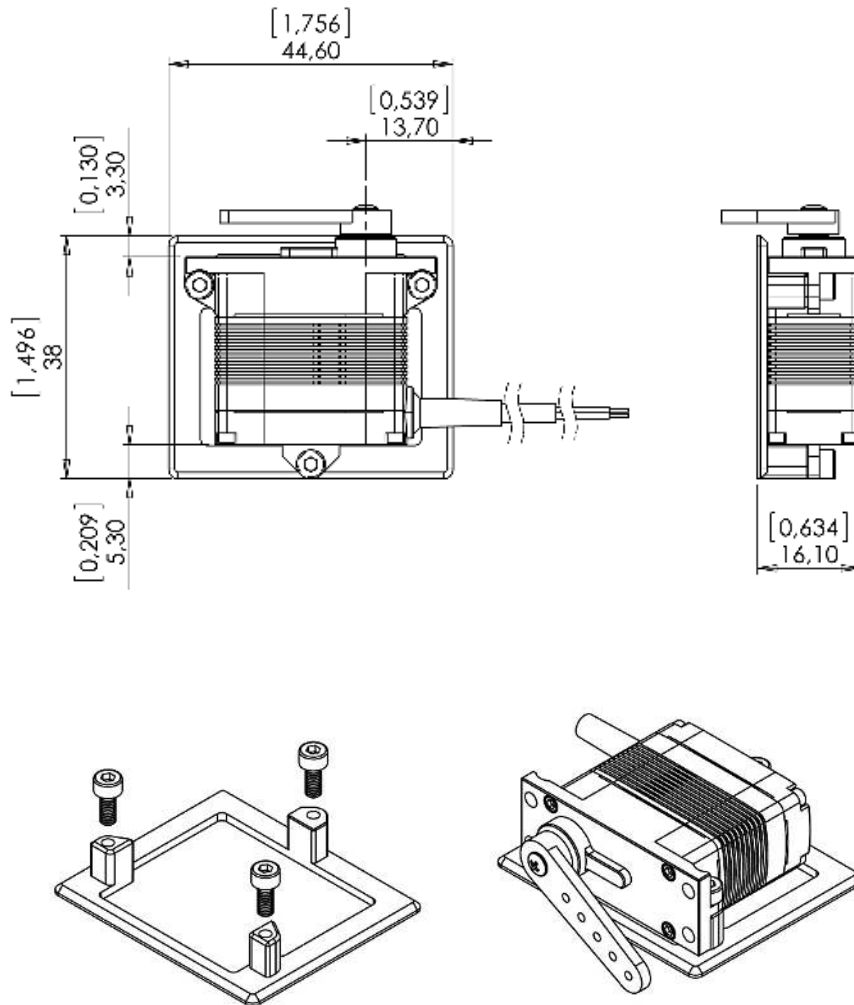

Mounting Frame shown with installed actuator.

Not to scale

Dimensions: [in] , mm

Content is subject to change without notice

Revision: D

9. Item Number System

DA	15	.	N	.	12	.	BLDC	.	250
Servo Class						Electrical Connection			
15 mm Class						250 shielded cable, open leads, length 250mm (10in)			
Supply Voltage						Motor Type			
6 V DC 06						BLDC brushless			
12 V DC 12									



Volz Servos GmbH & Co. KG

Kaiserstrasse 15
63065 Offenbach
Germany
Tel. +49-69-985580-0
Fax +49-69-985580-40

e-Mail mail@volz-servos.com

Website www.volz-servos.com