

Ellipse Series

MINIATURE HIGH PERFORMANCE Inertial Sensors



3rd
GENERATION

0.05°
RMS

ITAR
Free

IMU
AHRS
MRU
INS
VG



Navigation, Motion
& Heave Sensing



ELLIPSE SERIES sets up new standard for miniature and cost-effective inertial systems with an extremely rugged design, cutting-edge sensors, enhanced capabilities, and advanced algorithms.



Ellipse Series - High-end Technology in the Smallest Package

Robust L1/L2 RTK
with no extra charge

New 64bit processor
for maximum performance

Best performance and SWaP of its category

OEM version when size and cost matters

Easy integration
Get more out of your Ellipse with Qinertia Post-processing software (INS)



Ellipse Series is a successful line of industrial-grade inertial sensors known for their high level of robustness. This 3rd generation embeds a 64Bit microprocessor running latest generation algorithms. All the INS/ GNSS are now provided with multi-band RTK receiver for centimetric position and more accurate orientation.

Robust Heading within seconds
Immune to magnetic disturbances
Very short baseline down to 50 cm

Product Line



	Ellipse-A	Ellipse-E	Ellipse-N	Ellipse-D
Application	Motion Sensor	INS with your own GNSS receiver	INS for dynamic and automotive applications	INS for low dynamics and robust heading
Heading	Magnetic	Magnetic or GNSS	Magnetic or Mono-antenna GNSS	Dual antenna GNSS
Heave: 5 cm or 5%	●	●	●	●
Odometer aiding		Pulse / CAN OBD-II	Pulse / CAN OBD-II	Pulse / CAN OBD-II
Navigation		Navigation with external GNSS receiver	L1/L2 GNSS receiver 1 cm RTK GNSS Accuracy	L1/L2 GNSS receiver 1 cm RTK GNSS Accuracy
Post-Processing		●	●	●

Motion & Heave Monitoring



Data Georeferencing



Payload Orientation & Positioning



Features Inherited from High End INS/GNSS

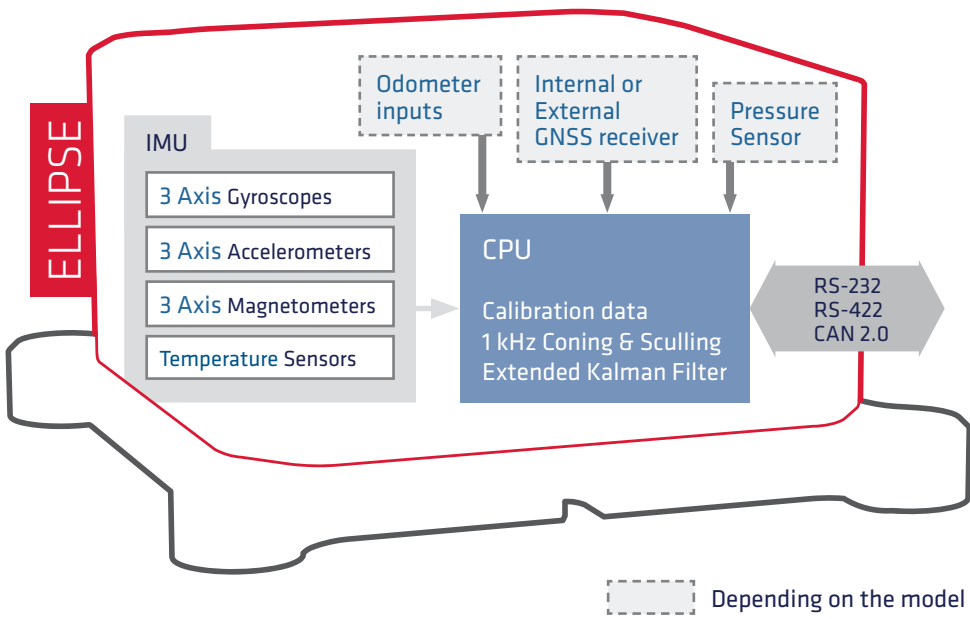

2-year Warranty

No Export Restriction

Drivers for:
 ROS
 PX4 autopilot

Best-in-class IMU	Advanced Algorithms	Easy Integration
<ul style="list-style-type: none"> » Industrial grade MEMS, superior vibration rejection » Extensive test and calibration from -40 to 85°C with individual calibration report » Integrated hard & soft magnetic disturbances calibration tools 	<ul style="list-style-type: none"> » Real-time fusion of inertial with aiding sensors (GNSS, RTK, DMI, DVL, etc.) » Robust position with invalid GNSS measurements detection and RAIM 	<ul style="list-style-type: none"> » Select your motion profile to automatically adjust Kalman filter and dynamic constraints for optimal performance » Automatic lever arm estimation (Enter rough lever arms, Ellipse will refine them automatically)



High Accuracy Heave

Ellipse Marine version delivers a 5-cm accurate heave which automatically adjusts to the wave period.

Ellipse is a cost-effective alternative solution for instrumented buoys, helideck, or boat motion monitoring applications.

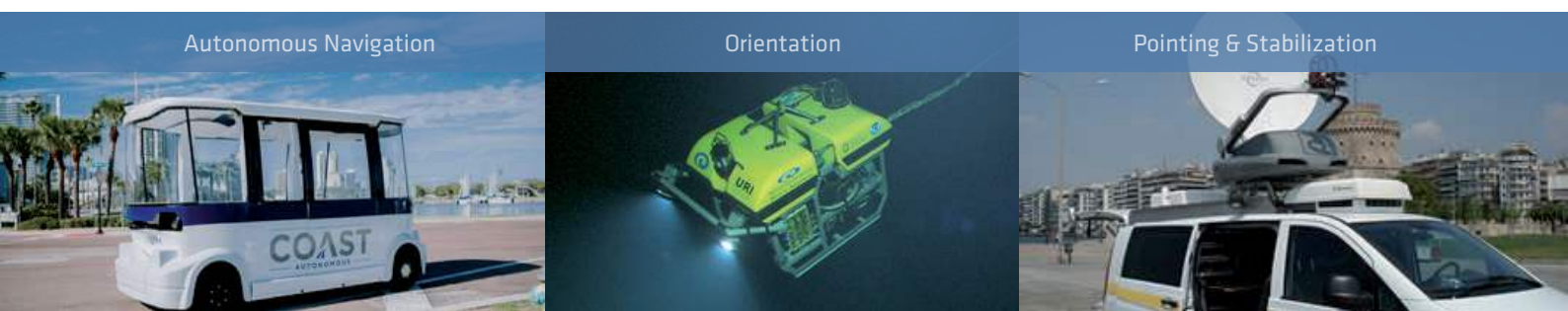

All you need to quickly get started



Development Kit

The Development kit comes with your first Ellipse. It contains:

- » Your Ellipse sensor calibration report
- » A Quick start guide
- » All required accessories depending on the chosen model (USB cable, Antenna(s), Development boards)

The SDK contains the sbgcenter which allows visualization, configuration, analysis, and export to Excel, Matlab, Google Earth formats as well as code examples for easy integration.

Services

As expert of inertial navigation, we are at your side, helping you to get the most of your sensor:

- » Free technical support by phone and email
- » Unlimited firmware updates
- » Dedicated support platform (Knowledge center, documentation, etc.)
- » Custom remote initiation or on-site training on demand

Qinertia

Get more with your Ellipse INS using Qinertia (in option):

- » Detailed analysis after the mission
- » Replay the sensor data with different configuration
- » Refine the mechanical installation (GNSS lever arm) to the centimeter level for improved real time behavior
- » Reach ultimate sensors performance using Forward/Backward/Merge processing

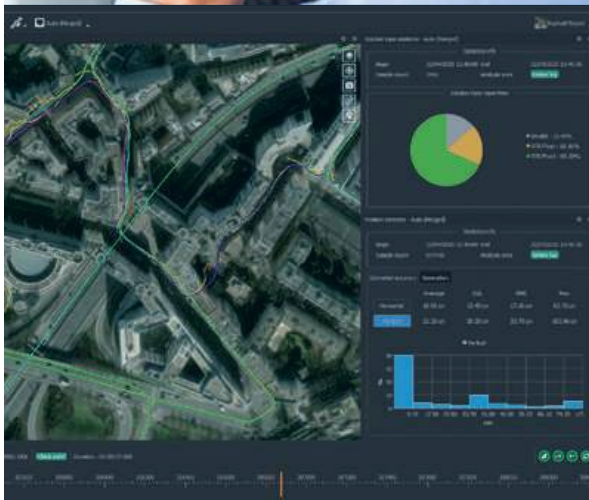

Dynamics Analysis

Navigation

Autonomous Industrial Vehicles



ACCURACY (RMS) 360° sensing in all axes, no mounting limitation

Model	A	E ⁽¹⁾ / N / D
Roll / Pitch	0.1°	0.1° SP 0.05° RTK 0.03° PPK ⁽⁴⁾
Heading	0.8° Magnetic ⁽²⁾	0.2° Dual antenna 2m 0.2° Single antenna with dynamics 0.1° PPK ⁽⁴⁾
Velocity ⁽³⁾	-	0.03 m/s
Navigation ⁽³⁾	-	1.2 m Single Point 1 m SBAS 1 cm RTK / PPK ⁽³⁾ + 1 ppm
Heave accuracy	5 cm or 5% - Valid for Marine version	
Heave period	Up to 15 s - Automatically adjusts to the wave period	

⁽¹⁾ With Supported GNSS receiver ⁽³⁾ Under good GNSS availability
⁽²⁾ Under homogenous magnetic field ⁽⁴⁾ Optional PPK = Post-processing Kinematic

INTERFACES

Available data	Euler angles, quaternion, velocity, position, heave, calibrated sensor data, delta angles & velocity, barometric data, status, GPS data, UTC time, GNSS raw data (Post-processing), etc.
Aiding sensors	GNSS, Odometer, RTCM
Output rate	200 Hz, 1,000 Hz (IMU data)
Main Serial Interface	RS-232, RS-422, USB - up to 921,600 bps
Serial protocols	Binary eCom, NMEA, ASCII, TSS
CAN interface	CAN 2.0A/B - up to 1 Mbit/s
Pulses	Inputs: Events, PPS, DMI (Direction or quadrature) Outputs: Synchronization (PPS) Model A/N/D: 2 inputs / 1 output Model E: 4 inputs / 2 outputs









SENSORS

	Accelerometers	Gyroscopes	Magnetometers
Gain stability	1000 ppm	500 ppm	< 0.5 %
Non-linearity	1500 ppm	50 ppm	< 0.1 % FS
Bias stability	± 5 mg	± 0.2 °/s	± 1 mGauss
Random walk Noise density	57 µg/√Hz	0.15 °/√hr	3 mGauss
Bias in-run instability ⁽¹⁾	14 µg	7 °/h	1.5 mGauss
VRE	50 µg/g ² RMS	1 °/h/g ² RMS	-
Alignment error	< 0.05 °	< 0.05 °	< 0.1 °
Bandwidth	390 Hz	133 Hz	22 Hz

⁽¹⁾ Allan Variance, @ 25 °C

MECHANICAL

Box version are IP68, resistant to dust and water.
OEM version are PCB mounted for tight integration.

Model	A	E	N	D
Box				
Size	46 x 45 x 24 mm	46 x 45 x 24 mm	46 x 45 x 24 mm	46 x 45 x 32 mm
Weight	45 g	47 g	49 g	65 g
OEM				
Size	29.5 x 25.5 x 11 mm	29.5 x 25.5 x 11 mm	29.5 x 25.5 x 16 mm	29.5 x 25.5 x 16 mm
Weight	8 g	8 g	17 g	17 g

All parameters apply to full specified temperature range, unless otherwise stated. Full specifications can be found in the Ellipse Hardware Manual available upon request.

ORDERING INFORMATION

Pick one of each category

MODEL

- A: AHR5
- E: Externally Aided INS
- N: INS with integrated RTK GNSS
- D: INS with dual antenna RTK GNSS

VERSION

- Marine: 8 g - 450°/s
- Land Air: 20 g - 450°/s
- High Dynamics: 40 g - 1000°/s

PACKAGE

- BOX RS-232 / 422
- BOX RS-232 / CAN
- OEM TTL

INTERNAL GNSS (N & D MODELS)

Features	SBAS, RTK, RAW
Signals	GPS: L1C/A, L2C GLONASS: L10F, L20F GALILEO: E1, E5b, BEIDOU: B1/B2
Update rate	5 Hz
Cold start / Hot start	< 24 s / < 2 s

PRESSURE SENSOR (models E/N/D)

Resolution	1.2 Pa / 10 cm / 0.3 ft
Pressure accuracy	± 50 Pa / ± 200 Pa Relative / Absolute

ELECTRICAL & ENVIRONMENTAL

Input voltage	5 - 36 V
Power consumption	A/E: < 300 mW N ⁽¹⁾ : < 600 mW D ⁽¹⁾ : < 900 mW
Specified temperature	-40 to 85 °C
Shock limit	500 g
Operating vibration	8 g RMS (20 Hz to 2 k Hz per MIL-STD 810G)
MTBF	218,000 hours

⁽¹⁾ Without GNSS antenna



SBG Systems is a leading supplier of inertial motion sensing solutions. The company provides a wide range of inertial solutions from miniature to high accuracy. Combined with cutting-edge calibration techniques and advanced embedded algorithms, SBG Systems products are ideal solutions for industrial & research projects such as unmanned vehicle control, antenna tracking, camera stabilization, and surveying applications.

PRODUCT LINES



Ellipse Micro



Ekinox Series



Apogee Series

SBG Systems EMEA (Headquarters)

Phone: +33 1 80 88 45 00

E-mail: sales@sbg-systems.com

SBG Systems North America

Phone: +1 (657) 845-1771

E-mail: sales.usa@sbg-systems.com

SBG Systems Singapore

E-mail: sales.asia@sbg-systems.com

www.sbg-systems.com